

THE JASON "JUPITER" STEREO PRE-AMPLIFIER

VOLUME 11
NUMBER 12
JULY
1958

The **RADIO Constructor**



RADIO • TELEVISION • AUDIO • ELECTRONICS

CRY BABY

BABY ALARM

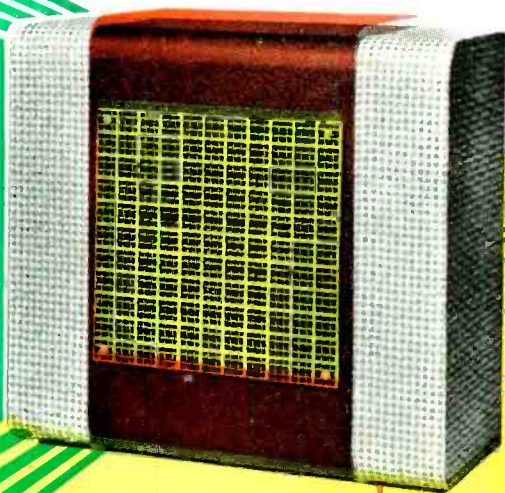

described by **E. Govier**

Included in this issue

"COMPANION" PRINTED CIRCUIT TRANSISTOR
RECEIVER

THE "MINI-METER" FREQUENCY METER, Part 2

TRANSISTORISED MICROPHONE PRE-AMPLIFIERS

THE DOUBLE SUPERHET

THREE-WAY REMOTE CONTROL SYSTEM

DATA
Publications 19

THE MODERN BOOK CO

The Radio Amateur's Handbook.
1958 ed. 32s. 6d. Postage 1s. 9d.

TV and Radio Tube Troubles. By S. Heller. 23s. Postage 1s.

TV Fault Finding. A Data Publication. 5s. Postage 6d.

Low-Cost High-Quality Amplifier. By P. J. Baxandall. 3s. 6d. Postage 6d.

Television Servicing. By G. N. Patchett. Vol. 1. 5s. Postage 6d.

Quality Amplifiers for A.C. Mains. A Data Publication. 4s. 6d. Postage 6d.

An Introduction to the Cathode Ray Oscilloscope. By H. Carter. 12s. 6d. Postage 9d.

MK Electronic Tube Handbook. 5s. Postage 1s.

The Gramophone Handbook. By P. Wilson. 15s. Postage 1s.

Television Explained. By W. E. Miller. 12s. 6d. Postage 1s.

Television Engineers' Pocket Book. By E. Molloy and I. P. Hawker. 10s. 6d. Postage 9d.

Magnetic Tape Recording. By H. G. M. Spratt. 55s. Postage 1s. 3d.

Fun with Radio. By G. Davey. 10s. 6d. Postage 1s.

Telecommunications Principles (In M.K.S. Units). By R. N. Renton. 45s. Postage 1/6

We have the Finest Selection of British and American Radio Books in the country
Complete catalogue 6d.

19-23 PRAED STREET (Dept RC) LONDON W2

Telephone PADdington 4185

CONSTRUCTORS CORNER

PERSONAL PORTABLE RADIO

Ideal for the holiday, hiking, fishing, camping, cycling, etc. Use it at home, at the office, in bed, or just anywhere.



30/-

TRANSISTOR COMPONENTS

Miniature A.F. Transformers, specially designed for coupling transistor output stages, fully coded, 7/6 each
Transistors, Red spot, 100% tested, 10/- each
Crystal Diodes, 100% tested, 2/6 each
Miniature Condenser, variable, single-hole fixing, 0.0004μF, 4/- each

ALL-WAVE RADIO



30/-

This 1 valve S.W. receiver can be built for 30/- from our list of components, which can be purchased separately. It includes valve and 1 coil covering 24-40 metres. Provision is made to increase to 2 or 3 valves if required, and all components are colour-coded so that the beginner can build this set quite easily.

Headphones, 1,000 ohms impedance, specially designed for above receivers, 14/- per pair

Power Unit type PUI. Input 250V a.c.; output 120V at 20mA, 6.3V at 1.5A. Ideal for small receivers, test equipment, etc. Kit of Parts 32/6
Built and tested £2 each

All components for the receivers advertised are sold separately. Full construction data, point-to-point wiring diagram, parts lists, etc., are available at 2/- for each receiver.

Postage: Under 10/-, 9d. Under 40/-, 1/6. Over 40/-, post free

R.C.S. PRODUCTS (RADIO) LTD

11 OLIVER ROAD (Mail order only) LONDON E17

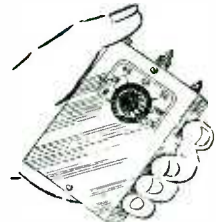

Transistor Pocket Radio, low cost and ideal for the beginner. Using the Variloopstick aerial (see below) and miniature condenser, the whole Medium Wave is covered. Fits the palm of the hand. 30/-

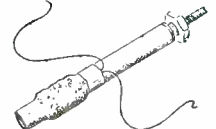

Variloopstick, specially designed for maximum transistor receiver performance, high 'Q' 4/6

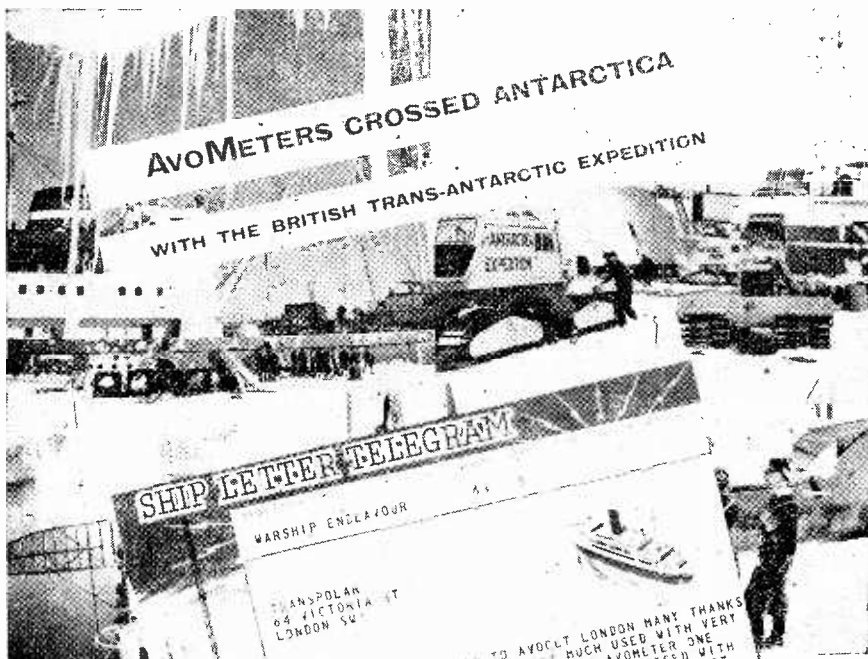

... and the AVO Instruments carried were identical in every way to the normal commercial models that are available to service engineers everywhere.

AVO LTD

Telephone: VICTORIA 3404 (9 lines)

AVOCET HOUSE • 92-96 VAUXHALL BRIDGE ROAD • LONDON • S.W.1.

Manufacturers of: ELECTRICAL, ELECTRONIC & NUCLEONIC INSTRUMENTS. DOUGLAS & MACADIE COIL WINDING MACHINES



Meet us at the

RADIO SHOW

Stand No. **60**

Aug 27-Sept 6
EARLS COURT

G.17

849

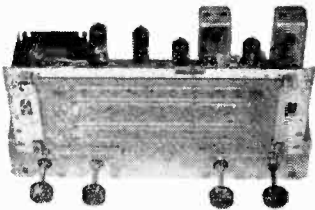

1958 RADIOGRAM CHASSIS

THREE WAVEBANDS FIVE VALVES
S.W. 16 m.-50 m. LATEST MULLARD
M.W. 200 m.-550 m. ECH42, EF41, EBC41
L.W. 800 m.-2,000 m. EL41, EZ40
12 month Guarantee. A.C. 200/250V. 4-way switch.
Short-Medium-Long-Gram. A.V.C. and negative feed-
back. 4.2 watts. Chassis 13 1/2" x 5 1/2" x 2 1/2". Glass dial
10" x 4 1/2" horizontal or vertical available. 2 pilot lamps.
Four knobs, walnut or ivory, aligned and calibrated.
Chassis isolated from mains. Immediate delivery.

BRAND NEW £10.10 Carr. 4/6

Special Cash with Order Discount 10%

TERMS: Deposit £5.5.0 and 6 monthly payments of £1
MATCHED SPEAKERS: 8" 17/6, 10" 25/-, 12" 30/-

**GARRARD 4-SPEED RECORD
CHANGERS RC120/H MKII MODELS***
Brand new and fully guaranteed 12 months

AUDIO PERFECTION

Designed to play 16, 33, 45, 78 r.p.m. records; 7", 10",
12". Lightweight Xtal pick-up, turnover head, two
separate sapphire styli, for standard and L.P. each plays
2,000 records. Voltage 200/250 a.c., latest mixer type

OUR PRICE £10.15.0 each. Post free

TERMS: Deposit £6 and 6 monthly payments of £1

MAKE A GARRARD RECORD PLAYER

AUDIO PERFECTION

Amplifier Player Cabinet. 18" x 13 1/2" x 8 1/2", with
ready-cut motor board **63/-**
2-valve 2-stage Amplifier, 6 1/2" speaker. 2 controls,
volume and tone, 3 watts **72/6**
3-valve 3-stage Amplifier, 6 1/2" speaker. 3 con-
trols, volume, bass and treble. 4 watts **95/-**

**GARRARD 4-SPEED SINGLE
RECORD PLAYER 4SP**

£8

AUDIO PERFECTION

**POST
FREE**

Designed to play 16, 33, 45, 78 r.p.m. Records, 7",
10", 12". Lightweight Xtal pick-up, GC2 turnover
head, two separate sapphire styli. Standard and L.P.

BUILD THIS REPRODUCER BARGAIN

SPECIAL SINGLE PLAYER KIT

COLLARO 4-speed Gram-Pick-up Unit **£4.12.6**
Handsome portable case 17 1/2" x 13 1/2" x 7" **£2. 5.0**
Ready-built 3 watt amplifier with two valves
and 7" elip. speaker, printed circuit **£3.12.6**

All available separately

£9.15.0 complete kit post free

I.F. TRANSFORMERS 7/6 pair

465 kc/s slug tuning miniature can 2 1/2" x 1" x 1".
High Q and good band width. By Pye Radio. Data
sheet supplied.
Wearrite M800 Midget I.F.S. 465 kc/s **12/6 pair**
Wearrite 550 Standard I.F.S. 465 kc/s **12/6 pair**

**48-HOUR
POSTAL SERVICE**

Our written guarantee with every purchase

C.R.T. ISOLATION TRANSFORMERS

For Cathode Ray Tubes having heater-cathode short
circuit and for C.R. Tubes with falling emission.

Type A. Low leakage winding. 25% boost on
secondary: 2V, or 4V, or 6.3V, or 10.3V, or 13.3V, with
mains primaries. 12/6

Type B. Mains input. Low capacity. Multi-output
2, 4, 6.3, 7.3, 10 and 13V. Boost 25% and 50%. This
transformer is suitable for all cathode ray tubes.
21/- each

Ditto for 6 volt tubes, only 17/6 each

Type C. Low capacity transformer for 2V tubes
with falling emission. Mains input. Output 2, 2 1/2, 2 1/2,
3V at 2A, 17/6 each

RESISTORS. Preferred values. 20% 10 ohms to
10 meg. 1/4W 4d., 1/2W 4d., 1W 6d., 1 1/2W 8d.

HIGH STABILITY. 1/4W 1%, 2/- All preferred
values 100Ω-10MΩ. Ditto 5% 100Ω-5MΩ 9d. each

5 watt } **WIRE-WOUND RESISTORS** { 1/3
10 watt } 25 ohms-10,000 ohms { 1/6
15 watt } 2/-

15,000 ohms-50,000 ohms. 5W, 1/9; 10W, 2/3

WIRE-WOUND POTS 3W Lab. Colvern, etc.
Pre-set min. TV type. Standard size Pots. 2 1/2"
Knurled slotted knob. Spindle, high grade. All
values, 100 ohms to 50k,
3/- each, 50k, 4/-
Ditto Carbon Track 50k
2 Meg. 3/-
CONTROL 100Ω, 3/-

MAINS TRANSFORMERS. Standard, 250-0-250,
80mA, 6.3V tapped 4V 4A, Rectifier 6.3V, 5V or 4V,
Ditto 350-0-350, 22/6; Miniature, 200V, 20mA, 6.3V
1 and 1A, 10/6; Small, 220-0-220, 50mA, 6.3V, 3A, 17/6;
Standard, 250-0-250, 65mA, 6.3V, 3.5A, 17/6; Heater
Trans., 200/250V, 6.3V, 1.5A, 7/6; Tapped Sec. 2, 4,
6.3V, 1.5A, 8/6; Secondary, 6.3V, 3A, 10/6.

O/P TRANSFORMERS. Heavy duty 50mA, 4/6.
Multi-ratio push-pull, 7/6. Miniature 3V4, etc., 4/6.
Small pentode, 4/6. Hygrade push-pull 7 watts, 15/6.
Mullard '5101' 6k or 8kΩ, 30/-

L.F. CHOKES 15/10H 60/65mA, 5/-; 10H, 85mA,
10/6; 20/15H, 120/150mA, 12/6; 5H, 250mA, 15/-

CRYSTAL MIKE INSERT by Acos

Precision engineered. Size only 1/8" x 1/8". Bargain
price 6/6 No transformer required

ALADDIN FORMERS and cores. 1" 8d., 3/8" 10d.
0.3" FORMERS 5937/8 and cans TV1/2. 3/8" sq. x 2 1/2"
and 3/8" sq. x 1 1/2", 2/- complete with cores

SLOW MOTION DRIVES. Epicyclic ratio 6-1, 2/3

TYANA. Midget Soldering Iron. 200/250V or 230/
250V, 16/9. **SOLON MIDGET IRON.** 25W, 24/-

MAINS DROPPERS. 3" x 1 1/2". Three adj. sliders.
0.3A 750 ohms, 4/3; 0.2A 1,000 ohms, 4/3

LINE COND. 0.3A 60 ohms per foot, 0.2A 100 ohms
per foot, 2-way, 6d. per foot; 3-way, 7d. per foot

MIKE TRANSF. 50:1, 3/9; 100:1, potted, 10/6
LOUDSPEAKERS. P.M. 3 ohm, 2 1/2" and 5", 17/6;
7" x 4" Goodmans, 21/-; 4" Hi-Fi Tweeter, 25/-;

8" Plessey, 19/6; 6 1/2" Goodmans, 18/6; 10" R.A., 30/-;
12" Plessey, 30/-; 8" 2.5k field tapped, o.p. trans., 24/6;
15 ohm Plessey 10W 12", with tweeter, 97/6;

Stentorian HF1012 10" 3 to 15 ohms 10W, 99/6
CRYSTAL DIODES. G.E.C., 2/-; GEX34, 4/-

40 CIRCUITS FOR GERMANIUM DIODES, 3/-
TUNING AND REACTION CONDENSERS
100pF, 300pF, 500pF, 3.6 each, solid dielectric

H.R. HEADPHONES 4,000 ohms, brand new, 16/6 pr.
SWITCH CLEANER FLUID, squirt spout, 4/3 tin
TWIN GANG CONDENSERS. 365pF, miniature,
1 1/2" x 1 1/2" x 1 1/2", 10/-, 0.0005 standard with trimmers,
9/-; less trimmers, 8/-, Midget 7/6; 50pF single, 2/6

JASON FM TUNER COIL SET, 26/-. H.F.
coil, aerial coil, oscillator coil, two i.f. transformers
10.7 Mc/s, detector transformer and heater choke.
Circuit and component book using four 6AM6, 2/-.
Complete Jason FM Kit, with valves and Jason
superior calibrated dial, £6.15.0, post free

RADIO COMPONE

Buses 133 or 68 pass door S.R. Stn. Selhurst

Aluminum Chassis. 18 s.w.g. Plain, undrilled, with 4 sides, riveted corners and lattice fixing holes, with 2½" sides. 7" x 4", 4/6; 9" x 7", 5/9; 11" x 7" 6/9; 13" x 9", 8/6; 14" x 11", 10/6; 15" x 14", 12/6; 18" x 16" x 3", 16/6

Volume Controls
Midget size
Long spindles. Guaranteed 1 year. All values 10,000 ohms to 2 Meg.
No Switch D.P. Switch 3/- 4/9
Linear or Log Tracks

80 Ω Coaxial Cable
Semi-air spaced Polythene insulated ¼" dia. stranded core. Ideal Band III Cd. yd Losses cut 50%

FRINGE QUALITY
Air-spaced Coaxial 1/6 yd

Coaxial Plugs 1/-
Sockets 1/-
Balanced Twin Feeder, per yd 6d., 80Ω or 300Ω
Twin Screened Balanced Feeder, 1/6 yd. 80 ohms
Trimmers. Ceramic, 30, 50, 70pF. 9d.; 100pF, 150pF, 1/3; 250pF, 1/6; 600pF, 750pF, 1/9. Philips. 1/- each
BLACK CRACKLE PAINT. Air drying, 3/- tin
P.V.C. CONN. WIRE, 10 colours, single or stranded. 2d. yd. Sleeving 1, 2mm, 2d., 2, 3mm, 3d., 6mm, 5d. yd
5" RADIO SCREWDRIVERS, 6d. each
NEON MAINS TESTER SCREWDRIVERS, 5/3
SOLDER RADIOGRADE, 3 yds 9d., ½lb 2/6
Sentercel Rectifiers. F.H.T. Type Flyback. Voltages: K3/25 2kV, 5/-; K3/40 3.2kV, 7/-; K3/45 3.6kV, 7/6; K3/50 4kV, 8/-; K3/100 8kV, 14/6
50 cps voltage 30% of above ratings

Mains Type RM1, 125V 60mA, 5/-; RM2 100mA, 6/-; RM3 120mA, 8/-; RM4 250V 275mA, 16/-; RM5, 20/-
Miniature Contact Cooled Rectifiers. 250V 50mA, 8/6; 250V 85mA, 9/6. Selenium Rect. 300V 85mA, 7/6
Coils. Wearite "P" type, 3/- each. Csmor Midget "Q" type, adj. dust core, from 4/- each. All ranges
Teleton. L. & Med. T.F.R. with reaction, 3/6
Ferrite Rod Aerials. M.W., 8/9; M. & L., 12/6
T.R.F. Coils A/HF, 7/- pair. **H.F. Chokes**, 2/6
Speaker Fret. Gold cloth, 17" x 25", 5/-; 25" x 35", 10/-
Expanded metal, silver, 15½" x 9½", 2/- each; **Tygan**. 4' 6" wide, 10/- ft; 2' 3" wide, 5/- ft

HANDY VOLTMETERS. 2" Twin Range 0-25V, 0-250V d.c. with leads and leather case, 9/6 each

Condensers. New stock, 0.001μF 7kV T.C.C., 5/6 ditto 20kV, 9/6; 100pF to 500pF Micaps, 6d.; Tubular 500V 0.001 to 0.01μF, 9d.; 0.05, 0.1, 1/-; 0.25, 1/6; 0.5, 1/9; 0.1/350V, 9d.; 0.01/2,000V, 1/9; 0.1/2,000V, 3/6
Ceramic Condensers. 500V 0.3pF to 0.01μF, 10d.
Silver Mica. 10% 5pF to 500pF, 1/-; 600pF to 3,000pF, 1/3; close tolerance (plus or minus 1pF), 1.5pF to 47pF, 1/6; ditto 1% 50pF to 815pF, 1/9; 1,000pF to 5,000pF, 2/-

NEW ELECTROLYTICS		FAMOUS MAKES	
TUBULAR	TUBULAR	TUBULAR	CAN TYPES
1/350V 2/-	100/25V 2/-	8-16/450V 5/-	
2/450V 2/3	8+8/500V 6/-	16+16/450V 5/6	
4/450V 2/3	16+16/500V 6/-	6,000μF 6V 6/6	
8/450V 2/3	CAN TYPES		
8/500V 2/3	Clips 3d.	32+32/350V 4/6	
16/450V 3/6	16/500V 4/-	32+32/450V 6/6	
16/500V 4/-	32/350V 4/-	64+120/275V 7/6	
32/450V 5/6	100/275V 5/6	60+100/350V 11/6	
25/25V 1/9	50+50/350V 7/-	100+200/275V 5/6	
50/25V 2/-	500/12V 3/-	1,000+1,000/6V 6/6	
50/50V 2/-	2,500/3V 4/-		

Full Wave Bridge Selenium Rectifiers. 2, 6 or 12V 1½A, 8/9; 2A, 11/3; 4A, 17/6. Free charger circuit
Charger Transformers. Tapped input 200/250V for charging at 2, 6 or 12V 1½A, 15/6; 2A, 17/6; 4A, 22/6

12/6 PURETONE RECORDING TAPE
1,200ft on standard fitting, 7" metal reels. Spare reels 7" metal, 2/3; 5½" plastic, 3/-; 7" plastic, 4/-

SUPERIOR 1,200ft plastic tape, 21/-, on 7" plastic reels. Quality guaranteed

TELETRON 'COMPANION'
PRINTED CIRCUIT TRANSISTOR THREE



99/6

See page 879

Pocket receiver kit, 4½" x 3" x 1½" complete with cabinet, all parts and transistors. Super-regenerative circuit. Local station receiver.

TRANSISTORS. Audio, 10/-; R.F. 2.6 Mc/s, 21/-; Mullard OC71, 20/-; Sub-miniature Electrolytics, 5½F 12V, 8½F 6V, 16½F 12V, 25½F 6V, 3/- each
R.E.P. MINI-7 transistor portable kit, 9½ gns.

THE HIGH GAIN BAND III TV PRE-AMP Tunable Channels 8, 9 and 10, Gain 17dB, Cascade Circuit. Complete kit with ECC84 valve, plans and instructions, 29/6 less power, or 49/6 with power pack. Plans only, 1/6

Wavechange Switches. 2 p 2-way, 3 p 2-way, short spindle, 2/6; 5 p 4-way 2 wafer, long spindle, 6/6; 2 p 6-way, 4 p 2-way, 4 p 3-way, long spindle, 3/6; 3 p 4-way, 1 p 12-way, long spindle, 3/6; wave change "MAKITS", 1 wafer, 8/6; 2 wafer, 12/6; 3 wafer, 16/-; 4 wafer, 19/6; 5 wafer, 23/-; 6 wafer, 26/6
Toggle Switches, s.p. 2/-, d.p. 3/6, d.p.d.c. 4/-

Morse Keys, good quality, 2/6. **Buzzers** 3/6
Valveholders. Pax. int. oct., 4d. EF50, EA50, 6d. B12A, CRT, 1/3. Eng. and Amer. 4, 5, 6, 7 and 9 pin, 1/-
MOULDED Mazda and int. oct., 6d., B7G, B8A, B8G, B9A, 9d. E7G with can, 1/6. VCR97, 2/6. B9A with can, 2/6. Ceramic, EF50, B7G, B9A int. oct., 1/-; B7G with can, 1/9; B9A with can, 2/9

SUPERHET COIL PACK 27/6
Miniature size high Q coils. Short, Med., Long. Gram. switching, with connection diagram. 465 kc/s i.f.

TV Fault Finding. Data Publications, 5/- each
Radio Valve Guide. Books 1, 2 or 3, 5/- each

TELETRON "AJAX" CRYSTAL SET
Complete kit with cabinet 4½" x 3" x 1½" and instructions. 15/-, or with pair of H.R. phones, 30/-

New boxed		VALVES		50-day Guarantee	
1R5	8/6	6K8	8/6	EA50	1/6
1S5	8/6	6L6	10/6	EABC8010/6	E1148 1/6
1T4	8/6	6Q7	10/6	EB91	6/6
2X2	2/6	6SA7	10/6	EBC33	8/6
35A	8/6	6SJ7M	10/6	EBC41	10/6
3V4	8/6	6SN7	8/6	EBF80	10/6
5U4	8/6	6V6G	7/6	ECC84	12/6
5Y3	8/6	6V6GT	8/6	ECCF0	11/6
5Z4	10/6	6X4	7/6	ECF82	11/6
6AM6	8/6	6X5	7/6	ECH42	10/6
6B8	5/6	757	10/6	ECL82	12/6
6BE6	7/6	12AH8	10/6	EF39	7/6
6BH6	10/6	12AT7	10/6	EF41	10/6
6BW6	10/6	12AU7	9/6	EF50	5/6
6CH6	10/6	12AX7	9/6	Equip.	
6D6	7/6	12BE6	9/6	EF50	8/6
6F6	7/6	12BH7	10/6	Sylv.	
6H6	3/6	12K7	8/6	EF80	10/6
6J5	6/6	12Q7	8/6	EF92	5/6
6J6	7/6	35Z4	9/6	EL32	5/6
6I7	8/6	80	10/6	FL84	10/6
6K6	6/6	607	6/6	EY51	12/6
6K7	5/6	954	1/6	EZ40	10/6

Please address all Mail Orders correctly as below
337 WHITEHORSE ROAD WEST CROYDON
Telephone THO 1665 Catalogue 6d.

NT SPECIALISTS
• P. 1/-, over £2 post free. C.O.D. 1/6 (Export C.W.O. post extra, na H.P.) OPEN ALL DAY (Wed. 1 p.m.)

CLYNE RADIO LTD.



"The Component Specialists"

ALL POST ORDERS AND CORRESPONDENCE TO
 162 HOLLOWAY ROAD · LONDON N7
 NOR 6295/6/7
 18 TOTTENHAM COURT RD. LONDON W1
 MUS 5929/0095

Callers welcome at both branches

"R.E.P. MINI-7" POCKET TRANSISTOR PORTABLE

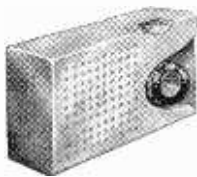

ALL NECESSARY COMPONENTS AT SPECIAL INCLUSIVE PRICE OF

£10.10.0

P. and P. 2/6

Medium Wave only

£9.19.6

P. and P. 2/6

STAR FEATURES

- ★ Utilises 7 specially selected transistors
- ★ Push-pull output
- ★ Hi-Grade 2½" p.m. loudspeaker
- ★ Ferrite slab aerial
- ★ Most attractive appearance
- ★ Exceptionally good quality output
- ★ Unequalled performance

Overall dimensions only 5½" x 3½" x 1½".
 Powered by two miniature 3V transistor batteries. Plastic case finished in dove grey with scarlet knobs.

PRINTED CIRCUIT TELETRON "COMPANION"

(As described in this issue.) All required components available at special **INCLUSIVE** price of **99/6** plus 1/6 p. and p.
 Constructional details and itemised price list **6d.** post free

CRY-BABY ALARM

(As described in this issue.)

This highly efficient unit is simple to assemble, extremely sensitive and may be installed in a matter of minutes. Completely **SAFE** employing a double wound mains transformer. Attractively finished in red and grey (washable) "Lionide" with cream plastic escutcheon. Size only 7½" x 3½" x 6¾". Supplied in kit form complete with mike at only **72/6** plus 2/6 p. & p. or assembled and tested **89/6** p. & p 2/6. Suitable mike flex available at 3d. yd. Instruction book and price list available separately 1/- post free. Note: For a.c. mains 200/250V only.

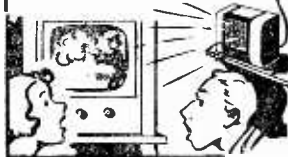
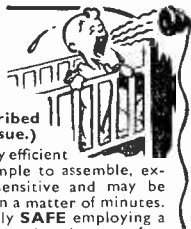

The "New Look RAMBLER"

SUPERHET BATTERY PORTABLE



VALVES

We have perhaps the most up-to-date valve stocks in the trade. A stamp will bring complete list of brand new imported valve types, fully guaranteed. P.T. paid. Also all usual surplus types available such as 6V6GT, etc.

Your summer holiday will not be complete without our most popular All-dry Battery Portable Superhet, now available with a new cabinet of even more attractive appearance. Finished in two-tone RED/GREY "Lionide," it is washable and unscratchable. The standard cream plastic top panel, engraved in red and green, completes the overall "air of quality." This receiver has everything: quality, sensitivity, economy and ample volume. Employs a high quality 5" loudspeaker and the following popular readily obtainable miniature valves: 3V4, 1R5, 1S5, 1T4. All necessary components, including cabinet, can be supplied, ex-stock, at the original Special Inclusive Price of **£77.0** plus 2/6 p. and p. (less batteries). Uses all-dry 1.5V l.t. (1/6), 90V h.t. (10/-). Easy-to-follow instruction booklet containing practical and theoretical diagrams and itemised price list available separately at 1/6 post free.

NOTE! **OPTIONAL EXTRA!** Latest ultra-low consumption "96" range valve; and simple modification data can be supplied for the "RAMBLER" at 8/6 extra.

RAMBLER MAINS UNIT

Enabling the above receiver to be used on a.c. mains, fits snugly into battery compartment. Completely self-contained in metal case measuring only 7" x 2½" x 1½". All necessary components ex-stock at only **47/6** plus 1/6 p. and p. or assembled and tested at **£35.0**. Instruction booklet and itemised price list available separately at 9d. post free.

R.E.P.—I-VALVE BATTERY RECEIVER

All components, as specified, available ex-stock, including headphones, at a Special Inclusive Price of **42/-** (less battery) plus 2/- p. and p. B114 battery 8/- extra. Instruction envelope and itemised price list available separately at 9d. post free.

PREMIER RADIO COMPANY

B. H. MORRIS & CO (RADIO) LTD

(Dept. R.C.7) 207 EDGWARE ROAD LONDON W2
Also 23 Tottenham Court Road London W1

Telephone
AMB 4033
PAD 3271

Open till
6 p.m. Saturday

Build the New "MAYFAIR" Televisor

which gives complete SAFETY to the constructor!

These Televisors use a double wound mains transformer which gives you complete safety from contact with the mains supply when handling the chassis or controls.

★ B.B.C. & I.T.A. DESIGN ★
WITH NEW TURRET TUNER

MAY BE BUILT FOR **£33.7.11** PLUS COST OF C.R.T.

Build in 5 easy stages. Full construction details available. Instruction Book 3/6 post free

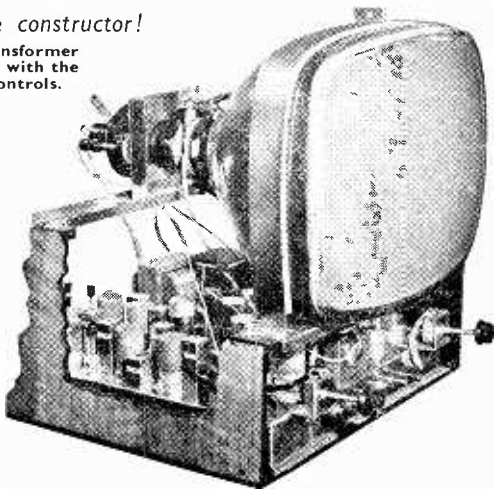

The "PETITE" PORTABLE

A new design from the firm with 45 years of experience in the supply of designs for the home constructor.

MAY BE BUILT FOR **£7.7.0** Plus p. & p. 3/-

Batteries Extra. H.T. 10/- (type B126) or equivalent, L.T. 1/6 (type AD35) or equivalent. ★ Size only 8" x 8" x 4 1/2"

★ Instruction Book 1/6.

G2AK FOR QUALITY AND SERVICE

HEADPHONES, H.R. type. 4,000 ohms. Very sensitive, only 12/6 pair, post 1/6. C.L.R. type (low res.) 8/6, post 1/6

BRITISH BREAST MIKES (carbon) Ideal for Mobiles, 7/6, p.p 1/6

PLUG-IN NOISE LIMITERS. 3-position limiting. No rewiring. Best with h.r. phones. Only 8/6, p. & p. 1/6

SEMI-MIDGET I.F. TRANSFORMERS. 10.7 Mc/s and 465 kc/s (can be used as 10.7 Mc/s and 465 kc/s only), 9/11 per pair, postage 9d.

HEAVY DUTY SHROUDED CHOKES. 10H, 150mA, 80 ohms. Only 10/-, p. and p. 2/6

We stock the full range of Denco, Repanco and Eddystone coils and components, and the most comprehensive range of Hi-Fi equipment in the Midlands, including Quad, R.C.A., W.B., Leak, Rogers.

ABSORPTION WAVEMETERS. 3.00 to 35.00 Mc/s in 3 switched bands, 3.5, 7, 14, 21 and 28 Mc/s. Ham bands marked on scale. Complete with indicator bulb. A must for any ham shack. Only 17/6 each post free

100 kc/s CRYSTALS. American makes, in 3-pin based holder. New condition, worth £3.10.0. Our price only 25/-, post free

SPECIAL OFFER!

DUAL RANGE VOLTMETERS 0-5V and 0-100V, Moving Coil, 1,000Ω/V; ranges can be easily extended. Complete with leads and prods; solid leather carrying case, 6 1/2" x 5" x 2 1/2"

A GIFT at 25/-, post free

CHOKES. 2.5mH, 120mA R.F. Chokes. Pie wound, 2/- each. Three or more—post free

N. TIONAL TYPE R-300U Pillar Mounting R.F. Choke, 1mH 300mA, 3/- each or 6 for 15/-

SHADED POLE MOTORS. For Tape Recorders or Gram Units. Adjustable voltage, 3-hole fixing. Only 15/- each or 27/6 pair, p.p. 2/-

RACK MOUNTING PANELS 19" x 5 1/2", 7", 8 1/2" or 10 1/2" black crackle finish, 5/9, 6/6, 7/6, 9/- respectively, p. & p. 2/-

AERIAL EQUIPMENT

COPPER WIRE 14g. h.d.; 140' 17/-; 70' 8/6; 7/25 stranded; 140' 10/-; 70' 5/- plus 2/- p. & p. RIBBED GLASS INSULATORS, 3" 1/6 each or 6 for 7/6. Postage and packing 1/6

TWIN FEEDER. 300 ohm Twin Ribbon Feeder, similar K25, 6d. per yard. K35B Telcon (round), 1/6 per yard. Post on above feeder and cable, 1/6 any length

PLEASE PRINT YOUR NAME AND ADDRESS

CHAS. H. YOUNG LTD Dept. 'R',

110 DALE END BIRMINGHAM 4 Telephone Central 1635

New stereophonic kits

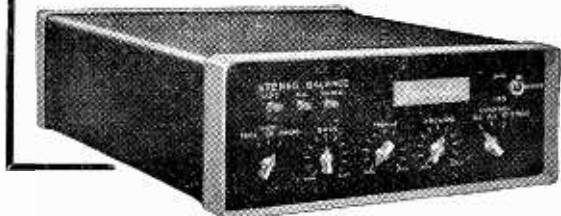

from



J.4-4

All parts include prepared chassis, but less 8 valves

£16.10.0

J.2-2

All parts as above but less 4 valves

£12.18.0

Two designs are offered. The first, Model J.4-4 (8 valves) is intended for the more experienced constructor to build, and has sufficient gain to play off a tape head. This is the model as designed by Mr. H. Lewis Yorke, of Cape Electrophonics, and described in Hi-Fi News. Model J.2-2 (4 valves) is a somewhat simpler version of the original design, and less complicated to build.

A special double amplifier is also available, the Jason J.2-10. This is virtually the original J.10 converted to stereo, and like the J.10 is intended for shelf mounting. All Jason Stereophonic equipment can be used also for single channel reproduction.

FULL DETAILS GLADLY SENT ON APPLICATION

Stereophonic Demonstrations every Saturday morning in our showroom

THE JASON MOTOR & ELECTRONIC CO 3-4 (E) GREAT CHAPEL STREET
OXFORD STREET LONDON W1
GER 0273/4



QUALITY AMPLIFIERS for A.C. Mains

The latest in the Data Book series (DB11). 64 pp., plus laminated plastic board cover. The contents include a selection of popular Quality Amplifiers, including the Mullard "3-3" and "5-10" Amplifiers complete with the very latest modifications. Amplifier designs to suit all needs and pockets are featured—a chapter dealing with the reproduction of records (an important part of quality reproduction) also being included. Full circuit and constructional details, together with a number of point-to-point wiring diagrams, make this book a welcome addition to the available literature on Hi-Fi.

Price 4/6 Postage 4d.

Published by

DATA PUBLICATIONS LTD

57 MAIDA VALE · LONDON W9

Telephone CUNningham 6141 (2 lines)

Telegrams Databux London

EMI

"HIS MASTER'S VOICE"

MARCONIPHONE · COLUMBIA

Announce

NEW PRACTICAL WAY OF LEARNING AT HOME

NEW— completely up-to-date methods of giving instruction in a wide range of technical subjects specially designed and arranged for self-study at home under the skilled guidance of our teaching staff.

NEW— experimental outfits and lesson manuals are despatched on enrolment and remain the student's property. A tutor is allotted to each student for personal and individual tuition throughout the course.

Radio and television courses, with which specially prepared components are supplied, teach the basic electronic circuits (amplifiers, oscillators, detectors, etc.) and lead, by easy stages, to the complete design and servicing of modern Radio and T/V equipments.

If you are studying for an examination, wanting a new hobby or interest, commencing a career in industry or running your own full-time or part-time business, these practical courses are ideal and may be yours for moderate cost. Send off the coupon to-day for a free Brochure giving full details. There is no obligation whatsoever.

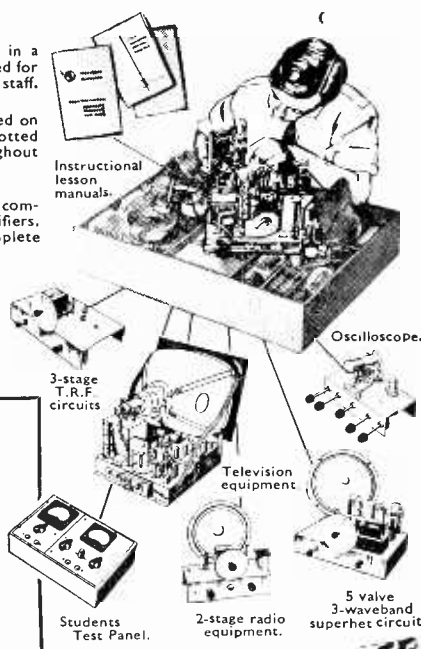

Courses with Equipment

RADIO · SHORT WAVE RADIO

TELEVISION · MECHANICS

CHEMISTRY · PHOTOGRAPHY

ELECTRICITY · CARPENTRY

ELECTRICAL WIRING · 'HI-FI'

DRAUGHTSMANSHIP · ART, etc.

E.M.I. Factories at Hayes, England.



EMI INSTITUTES

Fill in for **FREE BROCHURE**
 E.M.I. INSTITUTES, Dept. 179X, London, W.4.

Name..... Age (If under 21)

Address.....

I am interested in the following subject(s) with/without equipment (We shall not worry you with personal visits)

FREE

BLOCK CAPS PLEASE

IC 107

The only Home Study College, run by a World-wide industrial organisation.

P. P. COMPONENTS LTD

219 ILFORD LANE ILFORD ESSEX ILF 0295

1T4	8/9	12K7	8/9	EF42	8/9	RL37	1/9
4D1	6/9	12Y4	8/9	EF50	2/9	SP41	4/9
6AM5	3/9	35Z4	8/9	EF50 red	5/9	SP61	6/9
6AM6	7/9	35L6	8/9	EF80	8/9	T41	10/9
6B7	1/9	63SPT	2/9	EF85	8/9	U22	10/9
6B8G	3/9	77	3/9	EF91	7/9	UF41	8/9
6F12	7/9	21OVPT	5/9	EF92	3/9	UU6	7/9
6F14	8/9	7193	3/9	EL84	10/9	U52	8/9
6H6M	1/9	AR6(2V)	1/9	EZ40	8/9	VR65	6/9
6J5M	2/9	ARP35	3/9	EZ80	8/9	VT52	6/9
6K7M	3/9	CV1083	3/9	FW4/500		VT501	6/9
6SJ7M	8/9	D1	1/9		10/9	VV48	9d.
6V6M	8/9	DH76	8/9	KTW61	5/9	TT11	6/9
6P28	12/6	DK96	8/9	L410	1/9	W76	8/9
6SA7M	3/9	DF66	5/9	NR41	3/9	VW81	3/9
6SG7	3/9	EA50	1/9	PEN45	6/9	Z77	7/9
6SG7M	2/9	EABC80	9/6	PEN46	6/9		
8D2	3/9	EAF42	8/9	PEN220A3	3/9	UX Types	
8D3	7/9	EB34	1/9	PL82	8/9	18	3/9
8D7	8/9	EBC33	6/9	PL83	8/9	78	3/9
9D2	6/9	ECC81	8/9	PM202	1/9	25RE	3/9
12A6	8/9	ECH42	8/9	PP225	3/9		
12AT7	8/9	EF37	4/9	PY81	8/9	Barrettor	
12BE6	6/9	EF39	3/9	P61	6/9	301	3/9

Post on 1 Valve, 9d. Post on 6, 2/-

8" P.M. Speakers, 8/9. Ideal gift. If fitted in small cabinet. "Treat the lady at home." Fit one in kitchen or cupboard door. Post 2/9 with o/p trans. fitted, 10/-

Extension Speakers, 29/9. In attractive cabinet, complete with 8" p.m. speaker, lead and switch. Money back guaranteed if not completely satisfied. Carr. 3/6

Resistors, 6d. doz. 270 ohms, 1/4W ceramic. Post on 1 doz. 6d., on 4 doz. 1/-, on 10 doz. 2/6

Insulating Tape, 1/6. 75ft. x 3/4" wide. Post on 1 tin 9d. Post on 6 tins, only 2/-

Solder Reels, 1/6. On plastic spools. 60-40 3-core Ersin. 20ft. List price 5/-, Post 6d.

O/P Transformers, 1/3. Salvage guar. 2-5 ohms, matching pentode or tetrode. O/P valve. Post 1/9. 20 for £1, post on 20, 5/6

Headphones, 1/9. Single earphone and band. C-LR type. Grand bargain. Ideal crystal sets. Ext. on radio or t.v. Post 1/6

Coax. Cable, 6d. yd. Cut to any length. Good quality. Post on 20 yds 1/6. 45/- per 100 yds, post 3/6

Droppers, 9d. each. 750 ohms, 2 amp. Post 9d. 5/- per doz. post 2/6

Chassis, 1/- each. 6 or 8-valve latest type midget valve design for a.m. or f.m. New. Cadmium plated on s.w.g. steel 12 1/2" x 7 1/2" x 2 1/2". Post 1/9. 4 for 4/-, post 3/-, 12 for 10/-, carr. 5/-

Torch Lanterns, 6d. each. Ex-W.D. Including 2 bulbs. uses 803 battery. Post 1/6. 5/- doz, post 3/-, Crate of 48, 21/-, carr. 10/-

Volume Controls, 1/9. 1/4MΩ. Long spindle. New and boxed. Post 1/6

Relays, 1/9. 105F/1479 150 ohms. Break one make two. G.P.O. pattern. Used. All tested. P. & p. 1/-

Condensers, 9d. 32μF 450V wkg. Cardboard, new and unused. Post 1/-, 12 for 7/-, post 3/6

R.F. Filter Units, 1/9. G.P.O. specifications. Beautifully made in solid brass case. Fitted with in-out switch. Simply fitted in the aerial. Has two-stage tuning. HURRY! Limited stock. P. & p. 1/3

Gang Condensers, 1/9. 2 and 3-gang, salvage guar. 0.0005μF. Tested and guar. P. & p. 1/3

I.F. Transformers, 1/- pair. 465 kc/s. Tested and guar. P. & p. 1/-

TV Sider Controls, 9d. 10kΩ, 2kΩ only, wirewound. Post 6d. 4 for 2/6. Post 6d.

Rectifiers, 2/9. 250 volt, 100mA. Full or half-wave. Salvage guar. P. & p. 1/3

Piano Hinges, 1/6 pair. Chrome. New. 7" long. Post 6d.

Telephone Sets, 7/9. Ex-W.D. Wireless remote control unit EMK.11. New conditions, Morse tapper, switched, jack plugs, etc.; less phone. Carr. 1/6

Send 3d. stamp for **FREE** catalogue

Closed Thursdays

The Teletron "COMPANION"

Portable 3-Transistor Receiver
now available with printed
circuit

(See page 879 this issue)

Circuit diagram with
instructions available
from most advertisers
in this magazine, 9d.
post free

SAM MOZER LTD

288 Hedge Lane London N13

Telephone PALmers Green 1748

Sole Distributor to the Trade

Ask "ARTHURS" First

NOTE NEW ADDRESS AT

125 Tottenham Court Road
London WCI

Close to Warren Street Station

You will have the same service and obtain
all your requirements in Radio and Compo-
nents, Electrical Goods and Accessories and
Television as previously.

Test Instruments in stock include Avo,
Taylor Cossor—advance list on request.

VALVE MANUALS AVAILABLE
Mullard 10/6; Brimar No. 7 6/-;
Osram Part 1, 2nd Edition, 7/6
Post & Packing 9d. each extra

Arthurs first

Est.
1919

Proprietors ARTHUR GRAY LTD

Gray House
125 Tottenham Court Road
London WCI

Telephone EUSton 5802/3/4

◆ ◆ ◆ ◆ REPANCO ◆ ◆ ◆ ◆

HIGH GAIN COILS and QUALITY COMPONENTS for the constructor

TRANSISTOR COMPONENTS

- FERRITE SLAB AERIAL TYPE FS2.** A new super-sensitive aerial, Long and Medium Wave, specially designed for transistor portable receivers. Complete with fixing brackets. Length $5\frac{1}{2}$ " 12/6
- COMBINED OSCILLATOR AND 1st I.F. TRANSFORMER TYPE OT1** (315 kc/s), fully screened, $\frac{1}{8}$ " x $\frac{1}{8}$ " x $1\frac{1}{2}$ " 11/6
- 2nd I.F. TRANSFORMER TYPE TT2** (315 kc/s), $1"$ x $\frac{3}{8}"$ dia... .. 5/-
- 3rd I.F. TRANSFORMER TYPE TT3** (315 kc/s), $1"$ x $\frac{3}{8}"$ dia... .. 5/-
- PUSH-PULL INTER-STAGE TRANSFORMER TYPE TT4.** Ratio 1:1 ct. Stack $1\frac{3}{8}"$ x $1\frac{1}{16}"$ x $\frac{7}{16}"$ 8/6
- PUSH-PULL OUTPUT TRANSFORMER TYPE TT5.** Ratio 15:1 ct. Stack $1\frac{3}{8}"$ x $1\frac{1}{16}"$ x $\frac{7}{16}"$ 8/-

MINIATURE RANGE—For pocket receivers

- FERRITE SLAB AERIAL TYPE FS3.** Medium Wave only. With fixing grommets. Size $3"$ x $\frac{3}{8}"$ x $\frac{3}{8}"$ 7/6
- OSCILLATOR COIL TYPE X08.** Medium Wave only. Overall size $\frac{1}{2}"$ dia. x $1"$. Enclosed in Ferrite pots 5/-
- I.F. TRANSFORMER TYPE XT6.** Suitable for 1st and 2nd I.F. 455 kc/s. Size $\frac{1}{2}"$ sq. x $\frac{1}{16}"$ 10/-
- I.F. TRANSFORMER TYPE XT7.** Designed for 3rd I.F.T. or detector I.F.T. 455 kc/s. Size as XT6 10/-
- PUSH-PULL INTERSTAGE TRANSFORMER TYPE TT9.** Ratio 1:1 c.t. Radiometal Core. Size $\frac{3}{8}"$ x $\frac{3}{8}"$ x $\frac{1}{16}"$ 12/6
- PUSH-PULL OUTPUT TRANSFORMER TYPE TT10.** Ratio 8:1 ct. Matched to 3 ohm speaker. Size as TT9 12/6

Practical and Theoretical circuits enclosed with each Repanco Transistor Component

COILS AND TRANSFORMERS FOR TRANSISTORISED CAR RADIO

- | | | |
|---|---|---|
| Medium Wave Aerial Coil Type XMA16... .. 10/- | } | Interstage Transformer Type TT11 10/- |
| Medium Wave H.F. Coil Type XMF17 10/- | | Output Transformer (12 volt Radio) Type TT12... .. 12/6 |
| Long Wave Aerial Coil Type XLA18 6/9 | } | Output Transformer (6 volt Radio) Type TT13... .. 12/6 |
| Long Wave H.F. Coil Type XLF19 6/9 | | |
| Oscillator Coil Type X015 5/- | | |

All this range boxed with circuit and practical diagram of all-Transistor Car Radio

REPANCO EASY-TO-BUILD RECEIVERS

Constructors' Envelopes of easy wiring plans, instructions and detailed price lists of components

- THE HIWAYMAN** Envelope 1/6 (post 3d.)
Four-valve superhet Dual-range Portable using Ferrite Rod Aerial
- REPANCO ONE-VALVE** Envelope 9d. (post 3d.)
Beginner's Dual-range Radio Set for use with headphones
- REPANCO FM TUNER UNIT** Envelope 1/6 (post 3d.)
Using 4 EF91, 1 EB91, 1 EM80 Valves, Ratio Detector
- REPANCO "THREE DEE"** Envelope 9d. (post 3d.)
Dual-range Transistor Radio using 3 Transistors and Crystal Diode.
Amazing loudspeaker reception from $7\frac{1}{2}$ volt battery supply
- REPANCO "TRANSEVEN"** Envelope 1/6 (post 3d.)
A new 7 Transistor superhet Portable with preset station tuning using Repanco transistor components
- REPANCO "MINI-7"** Envelope 1/6 (post 3d.)
The amazing new transistor pocket portable radio with all the technical features of a standard receiver. Seven transistors, superhet circuit, fully tunable over medium wave. Size $5\frac{1}{4}"$ x $3\frac{1}{4}"$ x $1\frac{1}{4}"$

MAIL ORDER and TRADE—

RADIO EXPERIMENTAL PRODUCTS
LIMITED
33 MUCH PARK STREET COVENTRY
Telephone 62572

WHOLESALE and EXPORT—

REPANCO LTD
O'BRIENS BUILDINGS
203-269 FOLESHILL ROAD COVENTRY
Telephone 40594



Our specialised buying knowledge and reputation ensure a square deal and enables us to

offer the best for your money!

BAND III TV CONVERTER
180 Mc/s—205 Mc/s

Suitable London, Birmingham, Northern, Scottish and Welsh ITA transmissions

Mk. 2 Model. Latest Cascade circuit using ECC84 and EF80 valves giving improved sensitivity (12 dB) over standard circuits, built-in power supply a.c. 200-250V. Dimensions only 6" x 3", ht. 4". Simple and easy to fit—only external plug-in connections. Wired, aligned and tested ready for use. State channel required. Guaranteed. Bargain offer—good results or full refund, only **£3.19.6** Carr. and pkg. 2/6

Band I/Band III changeover switch and B.B.C. aerial socket can now be fitted and wired to the above converter for 8/- extra

R.E.P. MINI-7. Kit of parts for this popular pocket transistor portable, 9½ gns., p. and p. 2/6

CONDENSERS. Mica or S. Mica. All pref. values. 3Pf to 680Pf, 6d. each. Ceramic types, 2.2Pf to 5,000Pf, 9d. each. Tubulars, 450V, Hunts and T.C.C. 0.0005, 0.001, 0.005, 0.01 and 0.1, 350V, 9d.; 0.02, 0.05, 0.1, 500V Hunts, T.C.C., 1/-; 0.25 Hunts, 1/6; 0.5 Hunts, 1/9; 0.001 6kV T.C.C., 5/6; 0.001 20kV T.C.C., 9/6

RESISTORS. Pref. values 10 ohms 10 megohms, 20% tol., ½W, 3d.; ½W, 5d.; 1W, 6d.; 2W, 9d.; 10% tol., ½W, 9d.; 5% tol., ½W, 1/-; 1% h-stab., ½W, 2/-

PRE-SET W/W POTS. TV knurled slotted knob type. 25 ohms to 30,000 ohms, 3/-; 50,000 ohms, 4/-; 50,000 ohms to 2 Megohms (carbon), 3/-

S.T.C. RECTIFIERS. E.H.T. types, K3/25 2kV, 5/-; K3/40 3.2kV, 6/9; K3/45 3.6kV, 7/3; K3/50 4kV, 7/9; K3/100 8kV, 13/6, etc. Mains types: RM1 125V 60mA, 4/9; RM2 125V 100mA, 5/6; RM3 125V 120mA, 7/6; RM4 250V 250mA, 16/-; RM4B type 250V 275mA, 17/6, etc.

LOUDSPEAKERS. P.M. 3 ohm, 2½" Elac, 16/6. 3½" Goodmans, 18/6; 5" R. & A., 17/6; 6" Celes., 18/6; 7" x 4" Goodmans, 18/6; 8" Rola, 20/-; 10" R. & A., 25/-

SPEAKER FRET. Expanded bronze anodised metal; 8" x 8", 2/3; 12" x 8", 3/-; 12" x 12", 4/3; 12" x 16", 6/-; 24" x 12", 8/6, etc. **TYGAN FRET** (Murphy pattern): 12" x 12", 2/-; 12" x 18", 3/-; 12" x 24", 4/-, etc.

RECORD PLAYER CABINETS

Contemporary style rexine covered cabinet in two-tone grey and green. Size 18½" x 13½" x ht. 8½", fitted with all accessories, including speaker baffle-board and plastic fret. Space available for all modern amplifiers and auto-changers, etc. Uncut record player mounting board 14" x 13". Cut mounting boards available

Cabinet Price £3.3.0 Carr. and ins. 3/6

1-VALVE AMPLIFIER Mk. 1. 200/250V a.c. modern circuit with high gain EL84 output and double wound mains transformer, variable tone and volume controls, wired and tested with 6" speaker and o/p trans., complete with knobs and drilled ready to fit baffle-board in above cabinet. Only **£3.12.6**. Carr. and pack. 2/6

2-VALVE AMPLIFIER Mk 2. 200/250V a.c. Specification as above but a higher fidelity and greater output (approx. 3 watts) is obtained by using latest twin stage triode-pentode valve ECL82 and negative feedback tone control. Complete wired and tested as above, **£3.19.6**, carr. and pack. 2/6

We can only show a small selection from our vast stocks in this advert. Write now for full Bargain Lists., 3d.



RADIO COMPONENT SPECIALISTS

70 Brigstock Road Thornton Heath Surrey

Telephone THO 2188

Terms: C.W.O. or C.O.D. Post and packing up to ¼lb 7d., 1lb 1/1, 3lb 1/6, 5lb 2/-, 10lb 2/9

RECORD PLAYER BARGAINS

SINGLE PLAYERS. 4-speed BSR (latest model, TU9), 92/6; 4-speed COLLARO JUNIOR, £4.10.0; 4-speed GARRARD (4 S.P.), £7.1.0, carr. & ins. 3/6

AUTO CHANGERS. 4-speed BSR (UA8), £8.10.0; 4-speed COLLARO, £8.15.0; 4-speed GARRARD (RC120/4H/2), £10.5.0, carr. and ins., 4/6. All above models brand new and guaranteed. Fitted latest style lightweight Xtal P.U. with turnover head and twin sapphire styli

VOLUME CONTROLS

Log. ratios, 10,000 ohms—2 Megohms. Long spindles. 1 year guarantee. Midget Ediswan type.

No Sw. D.P.Sw.
3/- 4/9

Linear Ratio, 10,000 ohms—2 Megohms. Less switch, 3/- each. **Coax Plugs,** 1/2 **Coax Sockets,** 1/- **Couplers,** 1/3. **Outlet Boxes,** 4/6

C.R.T. HEATER ISOLATION TRANSFORMERS.

New improved types—mains prim. 200/250V tapped. All isolation transformers now supplied with alternative no boost, plus 25%, and plus 50% boost taps at no extra cost. 2V 2A type, 12/6; 6.3V 0.6A type, 12/6; 10.5V 0.3A type, 12/6; 13V 0.3A type, 12/6. P. and p. 1/6 Other voltages in course of production. Small size and tag terminated for easy fitting

L.F. CHOKES—10H 65mA, 5/-; 15H 100mA, 10/6; 10H, 120mA, 10/6; 20H 150mA, 15/6

OUTPUT TRANSF.—Standard pentode, 4/6; push-pull 12 watt, 13/6. Small pentode, 3/9. Fretted battery pentode (154, etc.), 4/6

ELECTROLYTICS—ALL TYPES—NEW STOCK

Tubular—Wire Ends	Can Types. Clips 3d. each
25/25V, 50/12V	8+8/500V Dub. 4/6
25/50V T.C.C.	8+16/450V Hunts 5/-
50/50V, 4/500V	16+16/450V T.C.C. 5/6
100/25V, 2/450V	32/350V B.E.C. 4/-
8/450V T.C.C.	32+32/275V Hunts 4/6
8+8/450 B.E.C.	32+32/450V T.C.C. 6/6
8+16/450V T.C.C.	250/350V B.E.C. 8/6
8/500V Dub.	100+200/275V 12/6
16/450V B.E.C.	3/6

MIDGET TRANSISTOR TYPES. 2½F, 4½F, 8½F 6V, 3/6; 6½F, 10½F, 16½F 3V, 3/6; 32½F 1½V, 3/6

8" P.M. SPEAKER (3 ohms)

Ex-Mfrs. Units: Rola, V.B. Celestion, etc. All recon- ditioned and guaranteed. Ideal ext. unit. Bargain, 7/6, carr. 1/6

VALVES—NEW BOXED—ALL GUARANTEED

1R5, 1T4, 7/6; 1S5, 1S4, 7/6; 3S4, 3V4, 8/-; 5Z4, 9/6; 6AT6, 8/6; 6K7, 6/6; 6K8, 8/6; 6C7, 8/6; 6SN7, 8/6; 6V6, 7/6; 6X4, 7/6; 6X5, 7/6; 7C5, 9/-; 7Y4, 8/6; DAF96, 9/-; DF96, 9/-; DK96, 9/-; DL96, 9/-; 35L6; 10/6; EAB80, 9/6; EB91, 6/6; EBC41, 10/6; EVC33, 8/6; ECC84, 12/6; ECH42, 10/6; ECH81, 10/6; ECL80, 12/6; EF41, 10/6; EF80, 10/6; EF86, 13/6; EF91, 8/6; EY51, 12/6; EZ40, 8/6; EZ80, 8/6; MU14, 9/6; PCC84, 10/6; PCF80, 10/6; PCF82, 10/6; PCL83, 12/6; PL81, 14/6; PL82, 10/-; PL83, 11/6; PY80, 9/6; PY81, 9/6; PY82, 8/6; U22, 8/6; U25, 12/6; UY41, 8/6

SPECIAL—1R5, 1T4, 1S5, 1S4 or 3S4 or 3V4 per set 27/6

Hours 9 a.m.—6 p.m., 1 p.m. Wed.

Wanted!

QUALIFIED MEN AND WOMEN

Industry and Commerce offer their best posts to those with the qualifications — appointments that will bring personal satisfaction, good money, status and security. As part of a modern industrial organisation, we have skilled knowledge of what is required and the best means of training personnel for its present day and future requirements. We specialise also in teaching for hobbies, new interests or part-time occupations in any of the subjects listed below. Write to us to-day for further information. There is no obligation of any kind.

PERSONAL & INDIVIDUAL TRAINING IN —

- | | | |
|---------------------------------------|----------------------------------|--------------------------------|
| Accountancy | Electronics | Production |
| Advertising | Electronic | Planning |
| Aeronautical Eng. | Draughtsmanship | Radar |
| A.R.B. Licences | Eng. Drawing | Radio |
| Art (Fashion, Illustrating, Humorous) | Export | Radio Amateur's (C&G) Licence |
| Automobile Eng. | General Certificate of Education | Radio & Television Servicing |
| Banking | Heating & Ventilating Eng. | Refrigeration |
| Book-keeping | High Speed | Sales Management |
| Building | Industrial Admin. | Sanitary Eng. |
| Business Management | Jig & Tool Design | Secretariats |
| Carpentry | Journalism | Shorthand & Typing |
| Chemistry | Languages | Short Story Writing |
| City & Guilds | Management | Short Wave Radio |
| Exams | Maintenance Eng. | Sound Recording & Reproduction |
| Civil Service | Mathematics | Telecommunications |
| Commercial | M.C.A. Licences | Television |
| Commercial Subjects | Mechanical Eng. | Time & Motion Study |
| Commercial Art & Drawing | Metallurgy | Tracing |
| Customs Officer | Motor Eng. | Welding |
| Draughtsmanship | Painting & Decorating | Workshop Practice |
| Economics | Photography | Works M'gement and many others |
| Electrical Eng. | P.M.G. Cert. | |
| Electrical Installations | Police | |
| | Production Eng. | |

OUR BACKGROUND!

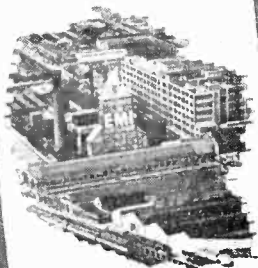

The E.M.I. Factories at Hayes, England.

Also courses for GENERAL CERTIFICATE OF EDUCATION, A.M.I.H.&V.E., A.M.S.E., A.M.Brit.I.R.E., A.M.I.Mech.E., A.M.I.E.D., A.M.I.M.I., A.F.R.Ae.S., A.M.I.P.E., A.M.I.I.A., A.C.C.A., A.C.I.S., A.C.C.S., A.C.W.A., City & Guilds Examinations, R.T.E.B.Serv. Cert. R.S.A. Certificates, etc.

NEW! Courses with **PRACTICAL EQUIPMENT** IN RADIO · TELEVISION · MECHANICS · CHEMISTRY · ELECTRICITY · DRAUGHTSMANSHIP · PHOTOGRAPHY, ETC., ETC.

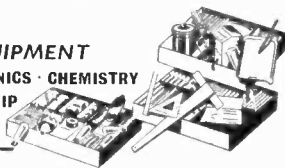

The only Home Study College
operated by a world-wide
manufacturing organisation

EMI

INSTITUTES

POST THIS TODAY

E.M.I. INSTITUTES, Dept. 179K, London, W.4

NAME _____

AGE (if under 21) _____

ADDRESS _____

I am interested in the following subject(s) with/without equipment _____

July/58 _____

(We shall not worry you with personal visits).

FREE

BLOCK CAPS PLEASE

IC 92

The only Home Study College run by a World-wide industrial organisation

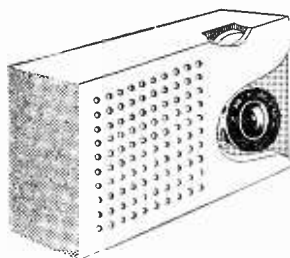

HOME RADIO OF MITCHAM

have all the parts for the

AMAZING NEW "MINI-7"

This 7-transistor superhet pocket portable, with a 2½" speaker, gives guaranteed results on its internal ferrite rod aerial.

It can be assembled in four stages, from standard components which are available from our stock, with the aid of point-to-point diagrams and wiring instructions (1/9 post paid).

STAGE ONE		STAGE TWO		STAGE THREE		STAGE FOUR	
Repanco 17/S group board	5/-	Repanco TT9	12/6	Resistors, miniature, 4d. each.		Repanco ferrite slab aerial type	
Repanco XT6 i.f. trans. (2)	£1	Repanco TT10	12/6	256 ohms, 1 4.7k.		FS3	7/6
Repanco XT7 i.f. trans.	10/-	2 x 60pF trimmer	1/9	2 47k, 2 10k, 2 1k, 1 3.3k, 1 6.8k	3/8	Rola/Celestion 2½" speaker C.25	£19.00
Repanco XO8	5/-	Crystal diode	1/3	0.01µF 150V type W99 or similar size (2)	1/6	L.F. transistors, Red spot (4 required at 8/- ea.)	£1.12.0
Jackson "00" twin gang (208 x 176)	9/6	Resistors, miniature, 4d. each	8d.	0.1µF 150V	9d.	Vidor V.0038 3V batteries (2 required at 10d. ea.)	1/8
10k volume control with s.p. switch	5/-	100µF 6V	2/9	8µF 15V TCC		Grey plastic case with scarlet control knobs	16/-
Resistors, miniature, 4d. each.	1/4	8µF 6V or 15V	3/-	CE67B, Mullard AO5705-8 (3 required, 3/6 each)	10/6	Complete Stage 4	£4.0.0
R.F. transistors, White spot (3)	£2.15.6	300pF 5% miniature condenser	9d.	Complete Stage 3	13/6		
Complete Stage 1	£5.0.0	Complete Stage 2	£1.12.6	Complete Kit	£10.18.6		

Complete set of additional sundries 3/-

All parts are available separately

Please add sufficient postage

HOME RADIO

(MITCHAM) LTD

187 LONDON ROAD, MITCHAM, SURREY

Tel: MITcham 3282

Build the... COOPER-SMITH B.P.I. HIGH FIDELITY 10-12 Watt AMPLIFIER and CONTROL UNIT

(as described in this Magazine)

Mr. A. Clarkson, of Scunthorpe, writes:

"My previous amplifier was a — type which I thought was very good and with a level output response. When I had finished the B.P.I. I switched on with the output connected to an old speaker . . . after waiting for the amplifier to warm up I thought something must be wrong as I couldn't hear any sound from the speaker. On touching input socket I nearly jumped off the floor, the click in the speaker was so loud. I had been expecting a slight hum when the set was warmed up but the background noise was quite silent. On connecting up the f.m. tuner my reaction was one of startled amazement. I had never heard the top notes properly on my old amplifier. This was a revelation and I guess I know now what hi-fi really is. Many thanks for a really fine amplifier. I felt someone ought to be shot on your staff because the job wasn't being advertised properly. An amplifier of this class and price should have been headline news in all the radio technical papers. . . . Another great point in your favour is your return post service and prompt reply to queries. It makes dealing with a firm like yours a pleasure."

The above letter may be inspected at our address.

See December, January and February numbers or send 2/8 for Radio Reprint which gives full instructions, additional material and price list of parts

Complete kit of parts for Amplifier (including valves) £12.12.0
 Complete kit of parts for Control Unit (including valves) £8.3.0

ANY PART SOLD SEPARATELY

CARRIAGE FREE IN U.K.

H. L. SMITH & CO. LTD

287/9 EDGWARE ROAD • LONDON W2 • Telephone Paddington 5891

The

Radio Constructor

incorporating THE RADIO AMATEUR



VOL. 11 No. 12

JULY 1958

ANNUAL SUBSCRIPTION 25/- (including postage)

CONTENTS

Editor
C. W. C. OVERLAND, G2ATV

Associate Editor
A. C. GEE, G2UK

Business Manager
J. H. BURROWS, A C A

Advertising Manager
F. A. BALDWIN, A M I P R E

Offices
57 MAIDA VALE LONDON W9

Telephone
CUNNINGHAM 6141
(2 lines)

Telegrams
DATABUX, LONDON

- 862 Suggested Circuits: A Three-Way Remote Control System, *by G. A. French*
- 865 Two-Way Radio in South Africa
- 866 In Your Workshop
- 870 Can Anyone Help?
- 871 Understanding Television, Part 7, *by W. G. Morley*
- 879 The Teletron "Companion" Printed Circuit Transistor Receiver, *described by S. Bennett*
- 884 The "Jupiter" Stereo Pre-Amplifier, A Jason design, *by G. Blundell*
- 894 The "Cry Baby" Alarm, *described by E. Govier*
- 899 The "Mini-Meter", a Frequency Meter for the Beginner, Part 2, *by James S. Kent*
- 904 Radio Miscellany, *by Centre Tap*
- 907 The Double Superhet, *by F. G. Rayer*
- 910 Transistorised Microphone Pre-Amplifiers, *by C. M. Pearson, B.Sc.*
- 912 The National Radio Show—Preliminary List of Exhibitors

NOTICES

THE CONTENTS of this magazine are strictly copyright and may not be reproduced without obtaining prior permission from the Editor.

ARTICLES appearing in this magazine which describe kits are inserted only on condition that such kits, or special components thereof, are freely available at a trade discount to all retail advertisers.

OPINIONS expressed by contributors are not necessarily those of the Editor or proprietors.

THE EDITOR invites original contributions on construction of radio subjects. All material used will be paid for. Articles should preferably be typewritten, and photographs should be clear and sharp. Diagrams need not be large or perfectly drawn, as our draughtsmen will redraw in most cases, but all relevant information should be included.

ALL MSS must be accompanied by a stamped addressed envelope for reply or return. Each item must bear the sender's name and address.

TRADE NEWS. Manufacturers, publishers, etc., are invited to submit samples or information of new products for review in this section.

QUERIES. We regret that we are unable to answer queries other than those arising from articles appearing in this magazine; nor can we advise on modifications to the equipment described in these articles.

ALL CORRESPONDENCE should be addressed to THE RADIO CONSTRUCTOR 57 Maida Vale London W9
REMITTANCES should be made payable to "DATA PUBLICATIONS LTD."

JULY 1958

861

Suggested Circuits

No. 92 A Three-Way Remote Control System

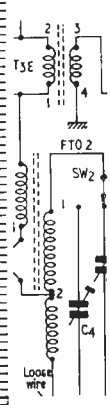

The circuits presented in this series have been designed by G. A. FRENCH, specially for the enthusiast who needs only the circuit and essential relevant data

AN INTERESTING FACET OF ELECTRONICS IS provided by the ability to control electrical operations from a remote position. Whilst such simple requirements as the switching on and off of a piece of equipment from a distant station are easy to resolve, it frequently happens that remote control over a number of complex operations is needed. In such instances ingenuity in design is required in order to reduce the number of lines between the remote, controlling, position and the local, controlled, position. If a radio link is employed between the two stations similar design ingenuity is needed to ensure that control may be obtained with the simplest possible form of signal.

A device which assists considerably in the achievement of multiple controls is the relay; and this lends itself particularly well to home-constructor applications owing to its relative cheapness (especially through surplus channels) and its simplicity. In this month's circuit two relays are employed in a remote control arrangement which enables three local circuits to be controlled from a remote position. Only two interconnecting wires are needed between the local and remote positions and one of these may be dispensed with

if suitable earth connections are available at both ends. An a.c. mains supply is required at the local position, but the remote control circuit proper is isolated by means of a mains transformer.

Circuit Description

The full remote control circuit is illustrated in Fig. 1, wherein it may be seen that the local position is that shown on the left and the remote position that shown on the right. One of the pair of interconnecting leads between the stations is shown dashed. This lead may be dispensed with if reliable earth connections are available at both positions. Such earth connections would be given by mains socket earth terminals and the like, since these would normally ensure a low ohmic resistance between the two stations. (As in any other electrical application, domestic gas pipes and fittings should *never* be used for earth connections.)

In Fig. 1 the two relays and their contacts are depicted in the "detached" manner of presentation. In simple relay circuits of the type which appear in radio publications it is customary to depict relays and their contacts by means of the "attached" method of presentation, in which the relay winding is

shown as a conventional coil and the contacts are illustrated directly above or below. Whilst this type of presentation enables the operation of the relay to be immediately comprehended, it causes difficulties whenever any complex switching arrangements are employed, this being due to the fact that the fixed positions in the circuit held by the contacts cause a large number of "crossovers" in the interconnecting circuit lines. In more complex circuits, therefore, it becomes less confusing to employ the "detached" circuit presentation.

and tells us also that the relay has three sets of contacts. The three contact sets are also shown in Fig. 1, these being designated A₁, A₂ and A₃. Unless otherwise specified, all contact sets in a "detached" diagram are illustrated in the position they take up when their relay is de-energised, and this convention is followed in Fig. 1.

We may now proceed to the functioning of the remote control circuit. The object of this circuit is to complete one of three controlled circuits by means of a remote switch. A fourth position of the remote

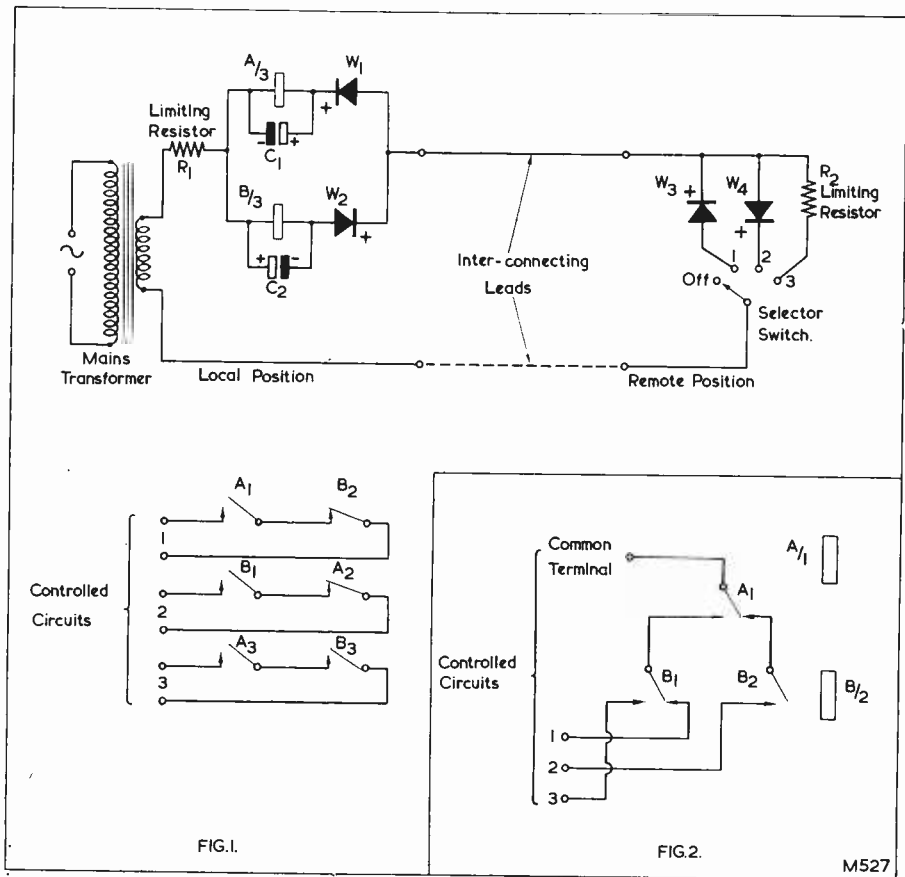

In "detached" circuits the winding of each relay is shown as a rectangle, the relay being identified by a letter over a number. The number indicates the quantity of contact sets employed by the relay. Thus, in Fig. 1, the reference A/3 indicates that the adjacent rectangle represents the winding of relay A,

switch enables all the controlled circuits to be switched off.

Commencing at this "off" position of the remote selector switch, we have the situation where no circuit exists across the inter-connecting pair of leads and, in consequence, where no voltage is applied to the relays.

The relays remain de-energised and none of the controlled circuits at the local station is completed.

Let us now examine what occurs when we move the remote selector switch to position 1. This at once causes an a.c. voltage from the secondary of the mains transformer to be applied to rectifier W_3 . Rectifier W_3 is connected such that only positive half-cycles appear on its upper terminal, these being applied to the upper interconnecting lead and, thence, to rectifiers W_1 and W_2 . Of these two rectifiers only one, W_1 , is connected up such that it may pass the positive half-cycles to its attendant relay winding. As a result a half-wave rectified a.c. voltage appears across the winding of relay A/3 and this becomes energised. (The purpose of the electrolytic condenser C_1 is partly that of smoothing the rectified a.c. applied to the relay winding, and thereby preventing contact chatter.) Summing up the above circuit operation, it may be stated that when the selector switch is set to position 1, half-wave rectified a.c. is applied to the winding of relay A/3, the current to this winding passing through two series rectifiers connected such that they pass current in the same direction.

When relay A/3 energises, its contact A_1 makes. Because of this, controlled circuit No. 1 becomes completed, the circuit path being made via contact A_1 (energised) and contact B_2 (de-energised). The other two controlled circuits are unaffected because, in the case of circuit No. 2, all that happens is that contact A_2 breaks; and, in the case of circuit No. 3, contact B_3 remains open despite the closing of contact A_3 .

When the selector switch is set to position 2, a.c. is applied to rectifier W_4 . In this instance it is negative half-cycles which are applied to rectifiers W_1 and W_2 , and it is W_2 which is now able to conduct the rectified a.c. In consequence relay A/3 de-energises and relay B/3 energises.

The energising of relay B/3 causes contact B_1 to make, controlled circuit No. 2 being completed by B_1 (energised) and A_2 (de-energised). Circuit No. 1 is broken, both by A_1 (de-energised) and B_2 (energised), and circuit No. 3 cannot be completed because A_3 is in the de-energised position.

Putting the selector switch to position 3 causes a.c. to be applied (via limiting resistor R_2) to W_1 and W_2 . Both rectifiers conduct, on alternate half-cycles, with the consequence that both A/3 and B/3 become energised.

This situation causes circuit No. 3 to be completed, the circuit path occurring via contacts A_3 (energised) and B_3 (energised). Circuit No. 1 is broken by B_2 (energised) and circuit No. 2 is broken by A_2 (energised).

A Simpler arrangement

The circuit of Fig. 1 enables three separate circuits to be controlled via a pair of remote leads, it being assumed that the three circuits must be isolated from each other.

It may quite feasibly happen that the three controlled circuits need not be isolated from each other, all that is required being that, say, a common source of potential be applied to each as desired. If this is the case it becomes possible to employ a common terminal for the controlled circuits, this being connected to three other terminals as desired.

A switching circuit capable of meeting this requirement is illustrated in Fig. 2. As may be seen, this is notably simpler than that of Fig. 1, the biggest saving being given by the reduced number of contact sets required on each relay. For instance, relay A/3 now becomes relay A/1, it needing only one set of "changeover" contacts. Relay B/3 becomes relay B/2, the requirement here being one set of "changeover" contacts and one set of "make" contacts. (The two relay windings still remain connected, of course, in the same manner as they were in Fig. 1.)

The switching circuit of Fig. 2 functions as follows. When the selector switch is in the "off" position neither relay energises, and the common terminal remains isolated from the other three terminals.

Putting the selector switch to position 1 causes relay A/1 to energise. In consequence the common terminal of Fig. 2 becomes connected to terminal No. 1 via contacts A_1 (energised) and B_1 (de-energised).

When the selector switch is set to position 2, relay A/1 de-energises and relay B/2 energises. The common terminal now becomes connected to terminal No. 2 via contacts A_1 (de-energised) and B_2 (energised).

In position 3 the selector switch causes both relays to energise. As a result, the common terminal connects to terminal No. 3 via contacts A_1 (energised) and B_1 (energised).

Practical Points

The constructor should have little difficulty in putting the circuits of Figs. 1 and 2 into practice, but the following points may be of assistance.

The types of rectifier employed in the W_1 to W_4 positions, and the mains transformer secondary voltage, depend upon the coil resistances of the relays employed and the energising voltages they require. An attractive proposition might be given by using relays capable of energising at some 10mA coil current, as this would then enable crystal diodes to be employed in the rectifier positions. Although not essential, it is desirable to employ the same rectifier type in all four positions. The condensers across the relay windings are required not only to prevent

contact chatter, as was mentioned above, but also to reduce any high reverse voltages which might be given when the current through a relay winding is switched off. To prevent sluggish de-energising, it would be preferable to employ condensers whose value is just sufficiently large to clear chatter.

Care should be taken to ensure that the rectifiers chosen do not have their maximum inverse voltage ratings exceeded. The maximum inverse voltage applied is equal to the rectified voltage appearing across the load plus the peak voltage of the applied a.c. In this circuit it should be safe to assume that the rectified voltage is approximately equal to the r.m.s. voltage across the transformer secondary. Thus, if this latter is rated at 20 volts, the peak inverse voltage would be $20 + (20 \times 1.414) = 48.28$. Any rectifier having a maximum peak inverse rating greater than, say, 55 volts would be more than safe here. Most current crystal diode types meet this requirement.

The limiting resistor R_1 is intended to limit the rectified current when any rectifier is switched into circuit. A simple method of calculating its value consists of assuming that whichever relay winding is connected into

circuit presents a temporary short-circuit. The value of R_1 then becomes that which causes slightly less than the maximum forward current specified for the rectifier type used to be passed when flowing through the forward resistances in series of W_1 and W_3 , or W_2 and W_4 . Details of maximum forward current and forward resistance will be available in the rectifier manufacturer's literature, and it should be assumed that the applied voltage is the peak value given by the transformer secondary. If the latter has a relatively high resistance, this may be considered as constituting part of the overall limiting resistance, and the value of R_1 may be reduced accordingly. The value of R_2 is equivalent to the forward resistance of either W_3 or W_4 . Since some readers may not be prepared to tackle the calculation of limiting resistor values it may be helpful to state that, if crystal diodes are used in the W_1 to W_4 positions, safe values for R_1 and R_2 would be 300 and 200 ohms respectively. The resistance of the mains transformer secondary, if greater than, say, 25 ohms, may be subtracted from the recommended value of 300 ohms for R_1 , enabling a lower value resistor to be used in this position.

TWO-WAY RADIO IN SOUTH AFRICA

TWO-WAY RADIO IS PLAYING AN increasingly important part as a time-saver—and even as a life-saver—in controlling a variety of government, civic and other activities in various large centres in the Union. In the Cape Peninsula this system of communication is now being used by the Table Bay harbour tugs, the Forestry Department, the municipal traffic department, the municipal fire brigade's central station, the South African Police, the city council's waterworks and cleansing departments, the Red Cross, the fire brigades outside the Cape Town municipality, the Automobile Association of South Africa—and even some of the building contractors and certain of the large taxi services. They are all working on different frequencies allocated by the Postmaster-General.

These organisations have found that two-way radio has greatly simplified and accelerated their work, with time and fuel wastage cut to a minimum. The vehicles using it vary from refuse lorries to the city's big new fire-engines, and the latest group of vehicles to be fitted with transmitters and receivers is the fleet of 30 ambulances serving the Cape Peninsula and the surrounding area. The first of these went "on the air" in the latter part of May.

In the case of the Red Cross, its radio-equipped ambulance—which to give it a greater range works on a lower frequency than most of the other vehicles using radio in the Cape Peninsula—has already helped to save several lives by ensuring prompt attention for patients being rushed to hospital. Examples of this were the use of "radio" ambulances at the scene of the Woodstock and Houboek rail smashes last year, when many people were injured and a number killed. There, through the Red Cross "home" stations, the hospital authorities were notified in advance how many patients to expect, as well as the nature of their injuries, so that the operating theatres could be prepared for their arrival.

A Cape Town municipal official said that the Cape Peninsula was one of the most difficult parts of the Union in which to operate two-way radio, because of the many "blind spots" caused by mountain ranges. For this reason, the Cape Town city council had authorised the putting into service of a special radio-equipped vehicle which would be used in emergencies to provide a link between municipal fire engines and the

continued on page 878

In your Workshop

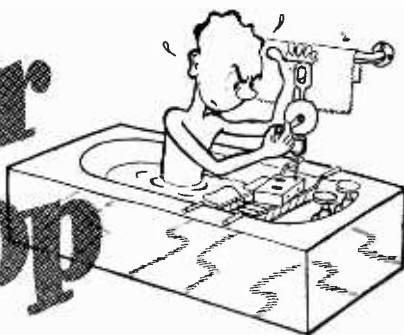

Aided by his able assistant, Dick, Serviceman Smithy continues to run the Workshop

"THE TIME HAS COME," COMMENCED SMITHY, slowly. He broke off for a moment, collecting his thoughts.

"The walrus said?" suggested Dick.

The Serviceman and his assistant were both sitting outside the Workshop in the hot summer sunshine, and were spending the last half-hour of a lazy lunch break in intermittent conversation. Dick was taking full advantage of the sun's warmth and had divested himself of his shirt and vest; but Smithy, with a sense of the dignity befitting his station, had only allowed himself the digression of placing on his head a handkerchief with a knot in each corner.

"Please don't interrupt," said the Serviceman severely. "You've made me forget what it was I was going to say. Ah yes, I remember now. What I was thinking of is that it's time I started to put you in the picture concerning some of the new devices and techniques you'll be bumping into in the latest receivers. You may have met some of these new things already, but they are still unfamiliar enough to merit a little nattering from me during the next quarter of an hour or so."

T.N.A. Wire

Dick settled himself more comfortably on his seat.

"Fire away," he said, a little drowsily. "I'm always ready to learn."

"Right," said Smithy. "Well, the first thing that comes to my mind is the considerably increasing usage in domestic receivers of what is called 'T.N.A. wire.' T.N.A. wire is ordinary tinned copper wire covered with nylon and, on the outside, a lapping in the opposite direction of acetate."

"That seems to ring a bell," remarked Dick in a tone which showed awakened interest.

"It should do," replied Smithy. "It was described several years ago in the R.E.C.M.F. report in *The Radio Constructor*."

"What are the advantages of T.N.A. wire?" asked Dick.

"It has two major advantages," said Smithy. "The first of these being that both the nylon and acetate coverings melt at normal soldering temperatures. The result is that the wire doesn't have to be stripped before it is soldered to its tag. All that you have to do is to lay it on the tag and apply a soldering iron plus solder. Both the nylon and the acetate melt away, leaving a small amount of black residue, and you then get a good solid joint to the tinned copper wire underneath."

"That seems to be something definitely worth having," commented Dick. "What's the second advantage?"

"The second advantage is conferred by the acetate lapping on the outside," replied the Serviceman. "After you've wound a coil with T.N.A. wire you then brush or spray it with acetone, this dissolving the acetate covering. The acetone only takes a few moments to evaporate, after which the acetate covering becomes hard once more. This time, however, it forms a continuous skin all round the coil, protecting the wire and holding the turns firmly in position."

"I can't see much advantage there," commented Dick. "What's the difference between applying acetone to a coil and applying any of the ordinary forms of coil dope?"

"There's the world of difference," said the

Serviceman. "Pretty well the only practicable dope which can be used with coils is polystyrene dope, and this consists of the basic polystyrene together with a solvent. Which means that, from the manufacturer's point of view, it becomes necessary to ensure that dope containers are kept well topped up with solvent, that the solution is thoroughly mixed, and that it receives continuous attention. If all you apply to a coil is acetone then these troubles are avoided altogether. Also, an acetone-brushed T.N.A. wire coil sets hard far more quickly than does a polystyrene doped coil. Yet a further advantage, albeit a minor one, is that if the acetone is applied to the wires leading from the coil proper to its tags, you get a hard film of acetate around the wire. This provides quite definite strengthening for the narrower gauges, and it also prevents the nylon covering from fraying and unwinding at the solder joint."

"Well," said Dick, as he slowly digested Smithy's information. "All that you have told me has shown that the use of T.N.A. wire helps the manufacturer. However, I'm not a manufacturer, I'm a putter-right of manufacturer's products! So how does T.N.A. wire help me?"

"I don't think," replied Smithy, slowly, "that you're looking at this from the right point of view. Provided that the reliability and performance of a product is not changed, anything which causes a drop in production costs is of assistance to the general trade. Things like television sets are not exactly cheap and it is to everyone's advantage if their cost can be cut by new ideas and methods."

"Apart from that aspect there is also the fact that, if you are interested in servicing a particular product, you should also be interested in the processes employed in making that product and in why the manufacturer employs such processes."

"I stand corrected," remarked Dick contritely. "Now and again I find myself becoming a little anti-manufacturer in my consideration of the set-makers' point of view. I suppose all servicemen get like that now and again."

"They do, indeed," chuckled Smithy. "And I suppose it's a human enough reaction. Anyway, let's get back to T.N.A. wire. As I said earlier, this was described in *The Radio Constructor* R.E.C.M.F. report several years ago, so it is not entirely new. You will probably have seen it used already in some of the later sets which have passed through your hands."

"At the time being T.N.A. wire is used, so far as I know, in solenoid—that is, single layer—coils only. I haven't yet heard of anyone producing wave-wound coils with it. The single layer coils most likely to be wound

with T.N.A. wire are found in the i.f. transformers for f.m. and t.v. receivers, and in Band I turret tuner coils. Also, in small r.f. chokes and components of that nature. To the best of my knowledge there is at present* no coloured T.N.A. wire available in this country, so that all the coils using T.N.A. wire will have 'natural' coloured wire. 'Natural' being white."

"There are quite a few shades of whiteness, you know," interjected Dick. "I've heard about them on t.v."

"It's a pity I ever helped you convert your set for Band III," laughed Smithy. "Anyway, T.N.A. whiteness is the whiteness which you thought was white before you used whatever it is that you do use."

"We don't use anything at all at home," volunteered Dick. "We just beat our dirty clothes on a flat stone."

"O.K., O.K.," said Smithy resignedly. "Now, if you're doing any fault-finding on coils using T.N.A. wire, here are some dodges which might be of help to you. First of all, it's a good plan to keep a small bottle of acetone handy. You can get it from any chemist. If you want to move the wire on a coil—say, because a lead-out has broken at the point where it leaves the coil and you want a little more wire to solder to—you can apply a little acetone at the point where you wish to commence operations. The acetone will cause the acetate to dissolve, whereupon the wire becomes easy to handle. After you've finished your solder joint or whatever repair you're carrying out (and don't forget that you can solder straight through the covering without having to strip it away) splash on a little more acetone. The wire will then become re-set in its new position."

"Do you honestly think it's worth getting in a bottle of acetone just for simple jobs like that?" asked Dick. "Couldn't you just as easily tear the wire out of the coil and use a little standard polystyrene dope on it afterwards?"

"Not really," said Smithy, "partly because it's much easier, quicker and neater to use the acetone; and partly because gauges thinner than 36 s.w.g. or so may be held so tightly in the 'acetated' coil that you would break the wire in attempting to pull it free."

"I see," remarked Dick. "Any other points?"

"Just one more," replied Smithy. "This is concerned with bad joints. We all know that badly soldered joints should never occur after a set has passed through its factory tests, but we also know that such joints do show up in practice every now and again. Sometimes, it's years before bad joints give any trouble, and you may occasionally get intermittent faults with them. So far as

* This particular episode was written in May, 1958.

joints with T.N.A. wire are concerned you can always make suspect joints reliably good by holding a soldering iron, with a little solder applied, on to them for just slightly longer than you need for soldering ordinary wire."

"Provided," said Dick, who knew Smithy's weaknesses, "that the tag the wire is connected to is capable of being soldered."

Smithy's face grew redder than was warranted by the heat of the day.

"Now don't get me started on that line again," he protested. All I will say on *that* particular subject is that somewhere in the country is a person who hates service engineers and who devotes his whole life to the design of solder tags which won't solder. I don't know who he is but if I ever meet him . . ."

Smithy left the sentence unfinished but Dick, who had heard the Serviceman's comment on unsolderable solder tags on many previous occasions, had little doubt about the manner in which Smithy would upset the erring tag designer's peace of mind.

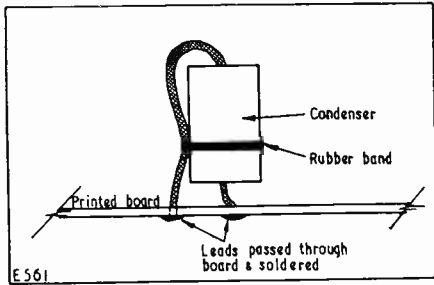

Fig. 1. To save space, tubular condensers are often fitted to printed circuit boards in the manner shown here. A rubber band, or length of adhesive tape, securing the longer wire to the condenser body helps to strengthen the mounting

Component Assemblies

A few moments passed before Smithy's thoughts returned to the subject he had originally introduced.

"Another new technique which is becoming used more and more," he continued, at length, "is occurring on printed circuits. As you may readily imagine, one of the snags of printed circuits is that all the components in a receiver have to be spread out on a flat board, with the result that they take up a great deal of area. In normally wired receivers you have three dimensions to play with, and you can save space by building upwards, as it were; but with printed circuits

you only have two dimensions in which to work. One solution towards saving space you will almost certainly have already encountered, this consisting of mounting large paper and electrolytic tubular condensers on end. (Fig. 1.) One lead of the condenser solders directly to the circuit copper whilst the other passes down over the outside of the condenser case. When replacing condensers mounted like this you have to observe the obvious precautions of taking care that you connect up with correct polarity, assuming an electrolytic condenser, and that you use the correct 'outside foil' connection, if the faulty component is a paper condenser in a very critical circuit position. Also, to ensure that the replacement condenser is positioned reliably you should secure the outside lead to the condenser case about two-thirds of the way down. A rubber band or a little adhesive vinyl tape will help here."

"What's vinyl tape?"

"It's more or less the same as p.v.c. tape," replied Smithy, "and it is a far better proposition for radio and t.v. repairs than the ordinary transparent tape you use for sticking papers together or sealing parcels.

"Another effort to overcome the tendency of printed circuits to spread has resulted in components such as small condensers and resistors appearing in complete little sub-assemblies of their own. These sub-assemblies may consist of a small board or tag-strip arrangement, quite possibly printed, to which the components are soldered. A row of lead-out wires appears at the bottom of the assembly, these passing through holes in the main circuit board, where they are soldered. In some cases the sub-assemblies may be quite simple, uncovered affairs, whereupon you can follow the circuit in which they appear and read component values at a glance. Alternatively, they may be covered or potted in some opaque sealing compound, in which case you can't see the components themselves, and you've had it so far as replacement of individual parts is concerned. Also, you will have to look at the service literature to find out what is hidden inside the sealing compound."

"A serviceman's life gets tedious sometimes, don't it?" observed Dick.

"Not entirely," replied Smithy. "The way I see the present situation is that domestic television and radio design is commencing to go through a basic evolutionary change and that we're just seeing the first signs in current printed circuit techniques. I know that the serviceman has to keep himself well up to date with present-day techniques, but this can hardly be described as being a great hardship. After all, we have to be adaptable because that's the first qualification of our trade. So far as changing production methods

are concerned, I often wonder what the next ten years will bring."

"How about condensers without wires?" asked Dick, a little sarcastically.

"Oh, we have those already!" chuckled Smithy. "The current types are intended for use in the large number of decoupling positions you get in t.v. i.f. strips and the like, where wide tolerance condensers around 1000 pF or so are required. These 'wire-less' condensers consist of a flat piece of ceramic having a trapezium-shaped outline, (Fig. 2 (a)), and having silvering on either side.* The two lots of silvering form the two plates of the condenser. These condensers are intended to be fitted into slots in a printed board (Fig. 2 (b)), and soldered over (Fig. 2 (c)). Dead easy!"

"Oh, yes," said Dick, brightening up again. "I remember reading about those."

"And you'll be seeing them soon," commented Smithy, "if you haven't done so already. All that a wire-wrap connection consists of is a bare length of tinned copper wire wrapped about seven or eight times around a specially shaped tag having sharp corners. (Fig. 3.) A special tool is employed for putting the wire on, and because of the tension with which it winds the wire around the tag you get a cold weld at each corner of the tag. The connection you get is, in fact, supposed to be better than that given by a soldered joint, and I seem to recall reading that a number of American telephone exchanges have been connected up with wire-wrap terminations.

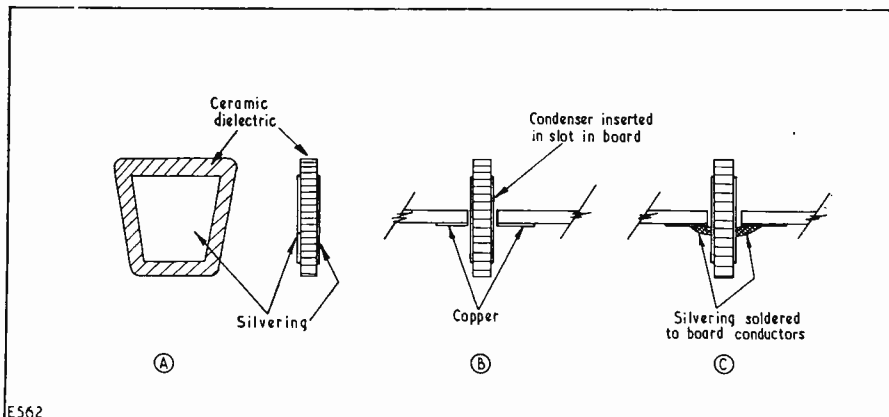

Fig. 2 (a) A ceramic "wedge" condenser, which is capable of being connected into a printed circuit without lead-out wires. (b) The "wedge" condenser is inserted into a slot in the board, as shown in this cross-sectional view. (c) Final connection is made by soldering the silvering to the printed circuit conductors

"Like everything else is," remarked Dick, a little gloomily, "once you know how."

Wire-Wrap

"And finally," said Smithy, "we come to the matter of connections which are made without solder."

"That's all we needed!"

"Cheer up," said Smithy. "If you'd read the American magazines I've been passing on to you lately, you'd realise that what are termed wire-wrap terminations are now 'old hat' in the States."

* Ceramic Wedge Capacitors, similar to that illustrated, have been introduced by A. H. Hunt (Capacitors) Ltd.

"If you ever have to undo a wire-wrap connection during servicing you should usually be able to untwist the wire from the tag without breaking it. You shouldn't get the impression, incidentally, that the ability to unwind a wire-wrap connection means that it is faulty; it merely infers that you have left a little of the wire's plating on the tag. (You may remember my telling you some months ago that you can similarly 'undo' a lightly soldered conventional joint.) When you re-make a wire-wrap joint you merely wind the wire once or twice around the tag and solder up in the normal way. Without the proper tool you cannot, of course, repeat the original wire-wrap connection."

Back to Work

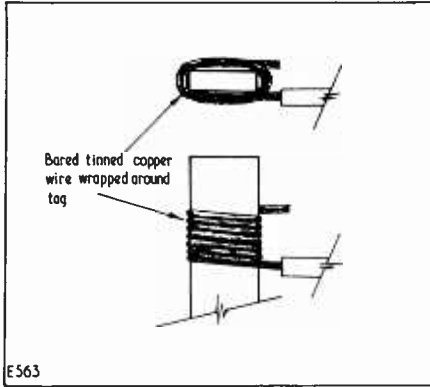

Fig. 3. A wire-wrap connection. No solder is required for connections of this type

"Well, we certainly seem to have had a good session on modern techniques," said Dick, as he struggled into his shirt preparatory to entering the Workshop for the afternoon's work. "And I think I will be better armed to meet these new things when they turn up on the bench. What have you got lined up for me this afternoon, Smithy?"

Smithy chuckled.

"Well, the first set is rather an oldie, I'm afraid," he said. "It's a battery three-valve straight, and I think that the PM2 output valve is losing emission. But the next set is much more modern. It's a five-valve super with real up-to-date side contact bottles."

Dick snorted in disgust.

"And he says you have to be adaptable!" he remarked, walking to the Workshop door.

"Sorry, Dick," laughed Smithy, "I'm only pulling your leg. In actual fact I've got a nice new printed circuit t.v. waiting for you, and it's got a really good intermittent in the gated a.g.c. circuit. That better?"

"I'm not too certain," said Dick, thoughtfully. "Perhaps I'll plump for the replacement PM2 job after all!"

Can Anyone Help?

Requests for information are inserted in this section free of charge, subject to space being available

G. P. LOWERY, "Fernleigh", Lowther Street, Penrith, Cumberland, wishes to know if anyone can sell him a copy of the November 1955 issue of *The Radio Constructor*.

* * *

D. POTTER, The School House, Monmouth School, Monmouth, has an ex-naval wire-recorder manufactured in New York about 1940, and wonders if any reader could either supply (purchase or loan) the circuit, or could advise him where such a circuit could be obtained.

* * *

R. SHAW, 269 Turncroft Lane, Offerton, Stockport, Cheshire, has a German receiver, made by or called "Mende", type number RENS 1374D. He is willing to reimburse anyone who can enable him to obtain the circuit, as a few adjustments appear to be necessary.

* * *

J. E. FARNSWORTH, 148 Fourth Avenue, Edwinstowe, Mansfield, Notts., asks for help in obtaining a service sheet or circuit details of the R.G.D. Model 1800, 12" Console Television.

A. R. L. MUNRO, 85 Winifred Crescent, Kirkcaldy, Fife, would be most grateful if anyone could inform him of any modifications they have carried out to improve the performance of the CR.100 receiver, in particular the fitting of modern all-glass valves such as EF85's in the r.f. amplifier stages. Any postage, etc., costs will gladly be refunded.

* * *

F. C. STYLES, 5 Stoke Lane, Patchway, Bristol, would like to purchase or borrow the circuit of the original Homelab signal generator—can anyone oblige?

* * *

R. MEYER, 34½ Dickenson Road, Longsight, Manchester, has purchased a CR.300 receiver which is faulty on the h.f. side, and would be glad if anyone could sell or lend him a circuit or manual of this receiver.

* * *

G. B. BRIERLEY, 99 Chessel Street, Bristol, 3, wishes to purchase or borrow the service sheets for the Models "B" or "D" Bendix Washing Machines. Please quote price, all costs will be refunded.

UNDERSTANDING TELEVISION

PART 7

By W. G. MORLEY

The seventh in a series of articles which, starting from first principles, describes the basic theory and practice of television

IN LAST MONTH'S ARTICLE, THE SECOND dealing with the subject of the cathode ray tube, we examined the basic principles of electrostatic deflection and focusing. In this issue, we shall continue our discussion of the cathode ray tube by dealing with magnetic deflection and focusing.

Magnetic Deflection

To understand the manner in which magnetic (or, to be more accurate, *electromagnetic*) deflection of the electron beam inside a cathode ray tube is obtained, it is first of all necessary to refer back to the basic precepts of electromagnetic theory.

Fig. 34 illustrates the lines of force which constitute a magnetic field between two magnetic poles. Such a field could be given between the two poles of, say, a horseshoe magnet. As occurred with the electrostatic fields which we considered last month, the individual lines of force shown in Fig. 34 have arrows which indicate their direction. In a magnetic field the direction of the lines of force is from a north pole towards a south pole.

When a conductor such as a piece of wire carries an electric current, a magnetic field is set up around it, this having the appearance

shown in Fig. 35 (a). In Fig. 35 (a) we see a cross-section through the conductor, and it is assumed that it passes at right angles through the surface of the paper. The conductor has a "+" sign in its centre, this

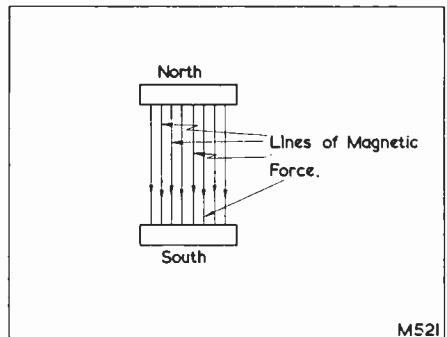

Fig. 34. The lines of force which appear between two magnetic poles. This diagram does not show the field which exists outside the space immediately between the two poles

indicating that the positive potential which causes current to flow is on the reader's side of the paper and that the negative potential is underneath the paper. In consequence, the flow of electrons which constitutes the electric current in the conductor is towards the reader. The lines of magnetic force appearing around the conductor, due to the flow of current in it, are circular in form and are concentric with the centre of the conductor itself. Their direction is clockwise.

those in the conductor of Fig. 35 (a). Each travelling electron has its own magnetic field around it and, in company with the case shown in Fig. 35 (a), the direction of each field is clockwise.

Let us now see what happens if we introduce our conductor of Fig. 35 (a) into the magnetic field of Fig. 34. This we do in Fig. 36 (a), and an interesting effect at once becomes apparent. This is due to the fact that, on the right hand side of the conductor,

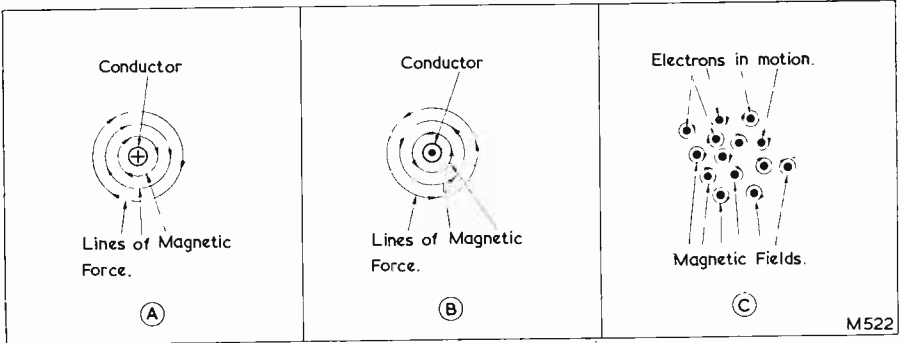

Fig. 35 (a) Cross-section through a conductor carrying an electric current, illustrating the circular lines of force which are set up around it. The current in the conductor is such that electron flow is towards the reader. (b) In this diagram, the current in the conductor is such that electron flow is away from the reader. In consequence the direction of the field is reversed. (c) Electrons in motion also cause the setting up of magnetic fields. In this diagram electrons are travelling towards the reader, and the direction of their individual fields is clockwise

In Fig. 35 (b) we see the same conductor. In this case, however, a dot is shown in the cross-sectional view, this indicating that the positive potential is now underneath the paper and that the negative potential is on the reader's side. As a result, electron flow in the conductor is away from the reader. Provided that the current has the same value as occurred in Fig. 35 (a) the strength of the magnetic field around the conductor will be unaltered. Its direction, however, will be reversed, this now becoming anti-clockwise.

The electron beam in a cathode ray tube consists, in actual fact, of a quantity of electrons travelling from a negative cathode towards a positive final anode. As such, the beam may be regarded in exactly the same light as an electric current in a conductor. A small quantity of the electrons in a cathode ray tube beam are shown in Fig. 35 (c) and it is assumed that these are travelling from a negative cathode, which is below the paper, to a positive anode which is on the reader's side of the paper. In consequence, these electrons will be travelling in the same direction (i.e. towards the reader) as were

the direction of the conductor's circular magnetic field is the same as that of the existing field. Because of this, the circular field assists the existing field in this particular area. On the other hand, the direction of the circular field on the left of the conductor is opposite to that of the existing magnetic field.

The immediate result of the interaction between the two fields is that the strength of the existing magnetic field to the right of the conductor becomes increased (due to the addition of lines of force in the same direction) whilst the strength of the existing field to the left of the conductor is decreased (due to lines of force in opposite directions cancelling each other out). The net result is that the magnetic field now commences to look like that shown in Fig. 36 (b).

The magnetic field of Fig. 36 (b) is obviously very different from that of Fig. 34, wherein the lines of force between the poles were straight. In Fig. 36 (b) the lines of force become distorted out of their natural state and they consequently exert a force upon the conductor which will result in their being able to return to their original condition.

In this case, the force exerted upon the conductor is to the left. (Another way of looking at the force exerted upon the conductor is to state that lines of magnetic force

conductor; and they exert a force to the left in consequence).

If the conductor of Fig. 36 (b) were free to move, the force exerted upon it would

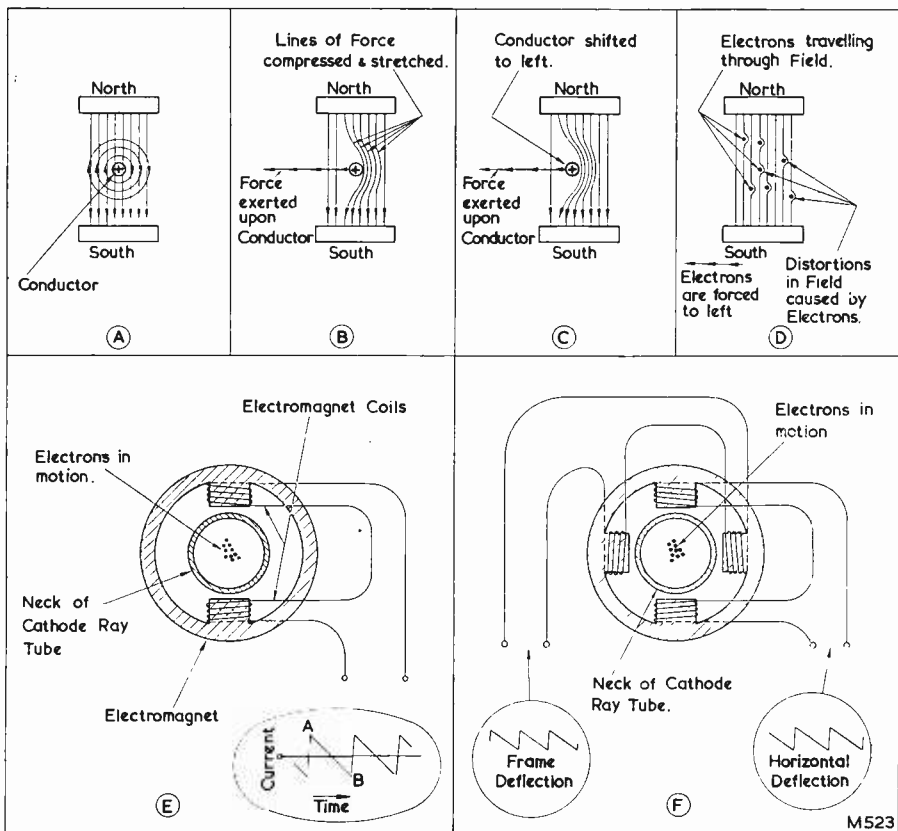

Fig. 36 (a) When the conductor of Fig. 35 (a) is inserted in the field of Fig. 34, their two fields, superimposed, take up the appearance shown here. (b) In practice, the combination of the two fields causes a distorted composite field to be built up. This results in a force being exerted upon the conductor, the force tending to move it to the left. (c) In this diagram the conductor has been partially moved to the left, but the force exerted upon it still exists. (d) Electrons moving through the field (towards the reader) are deflected to the left due to the combination of their fields and that through which they travel. (e) The electrons of (d) may be deflected as desired in the horizontal sense by replacing the fixed poles by the poles of an electromagnet. (The two coils are connected in series such that when one pole is North the other is South. Suitable parallel connection of the coils would give the same result.) (f) By adding two further poles to the electromagnet vertical deflection becomes possible

tend to follow the shortest path and that, if they have the same direction, they repel each other. The lines of force to the right of the conductor are longer, and are more compressed, than are those to the left of the

primarily cause it to be moved to a position such as that shown in Fig. 36 (c). However, this does not completely alleviate the distortion of the original field and the conductor still experiences a force in the left direction.

The force on the conductor will only cease when it has been pushed over to the weakest part of the field, at which point only negligible interaction can occur. (Although it is tempting to make the statement that the conductor is pushed right out of the field altogether, this would represent an untrue picture. The reason for this is that a magnetic field such as that of Fig. 34 has no finite boundaries, its fringes extending out into space until the individual lines of force become too weak to be effective or measurable. Due to the absence of a finite boundary it becomes customary to state that the conductor is forced into "the weakest part of the field").

If we had a beam of electrons passing through the magnetic field, as occurs in Fig. 36 (d), the same effect would be given as occurred with the conductor. In Fig. 36 (d) we assume that the electrons are travelling towards the reader, in which case they may be treated in the same manner as was the conductor of Fig. 36 (c), wherein electrons were, similarly, travelling towards the reader. The electrons of Fig. 36 (d) are forced by the magnetic field to move to the left. In this instance the amount of displacement suffered by the electrons depends upon the length of time they spend in the field, as well as upon the strength of the field itself.

The steps we have followed in Figs. 36 (a) to (d) now bring us to the point where we may consider the design of an electromagnetic deflection system for use with a cathode ray tube. The next stage consists of fitting an electromagnet such as that illustrated in Fig. 36 (e) around the neck of the cathode ray tube. This electromagnet provides a magnetic field similar to that we have been considering in Figs. 36 (a) to (d) with the difference that, because we use an electromagnet through whose coils we can cause to flow any current within reason that we choose, we can now control not only the strength of the magnetic field but also its direction. If, for instance, we energise the electromagnet in such a manner that its top pole becomes North and its bottom pole South, the electrons passing through its field will suffer a force which causes them to move, or to be deflected, to the left. If we reverse the energising current in the electromagnet coils such that the top pole now becomes South and the bottom pole becomes North, then the resultant field will exert a force on the electrons passing through it which will cause them to move to the right. We can further develop the system for our own purposes by applying a current to the electromagnet coils which follows the sawtooth waveform shown in the inset to Fig. 36 (e). If the uppermost point (A) of

this waveform corresponds to the case where the top pole of the electromagnet is North and the magnetic field is at its strongest in the downward direction, then the electrons passing through the field will suffer the greatest force causing them to move to the left. If the lowest point of the sawtooth waveform (point B) corresponds to the top pole being South with maximum field strength in the upward direction, then the electrons will suffer the greatest force causing them to be deflected to the right. Intermediate points along the sawtooth waveform will, of course, cause intermediate forces to act upon the electrons. Should the sawtooth waveform have a frequency equal to that employed at the transmitter for horizontal deflection, and should the two waveforms be synchronised together, then the electromagnet of Fig. 36 (e) would enable us to obtain the horizontal deflection of the beam which is required in a television system.

Our final step towards a complete electromagnetic deflection system consists of adding two more poles to the electromagnet in the manner shown in Fig. 36 (f). Since these poles cause a horizontal field to be given they will cause electrons passing between them to suffer a force either in the upward or in the downward direction according to the current flowing through their coils. If we make this current follow a sawtooth waveform which has the same frequency as, and is synchronised with, the frame deflection circuits at the transmitter we will now have achieved vertical as well as horizontal deflection of the beam of electrons. In consequence, we will be in a position to reproduce a transmitted television picture.

Before concluding on the subject of magnetic deflection there are one or two small points which need to be cleared up. The first of these is that it is advisable to examine a little more closely the path taken by an electron as it passes through a deflecting magnetic field. In Fig. 37 we see an electron following the path traced out by line ABCD. During its travel the electron suffers an accelerating force due to the final anode, this causing it to move, initially, along the straight line AB. At point B the electron enters the magnetic deflecting field, this being such that the electron suffers a downward-moving force. As a result, when the electron reaches point C its movement is partially forwards and partially downwards. After point C the electron leaves the magnetic field and continues to point D, on the surface of the screen, in a straight line once more. Fig. 37 may help to demonstrate the point that when the electron leaves the field its direction of motion is the resultant of two forces, one forward-acting due to the final

anode, and one downward-acting due to the magnetic field.

A further point which needs to be discussed is one which is exemplified by the fact that, in Figs. 36 (e) and (f), the electrons passing through the deflecting magnetic field were shown as a number of dots spread over a fairly large area. The reason for showing the electrons in this manner is that, when they pass through the deflecting field, they are divergent due to their having just left the second focusing lens. The next point at which the electrons will converge is at the surface of the screen itself. Because of the divergent nature of the electrons when passing through the deflecting field it is necessary to ensure that the latter is as regular as possible over that section through which the electrons pass.

assemblies, whilst functioning under the same principles as that shown in Fig. 36 (f), take up quite different forms. However, it would be impossible to enter into any detailed description of practical assemblies in the space of a single article, and this subject must be left to a later date.

Magnetic Focusing

The processes involved in magnetic focusing are somewhat more involved and complicated than in the case of magnetic deflection. The main reason for the complication is that electrons travelling through magnetic focusing fields encounter lines of force which are curved and which cause a number of different forces to be exerted.

Fig. 38 (a) illustrates part of the magnetic

Fig. 37. The path followed by an electron when passing through a deflecting magnetic field. This diagram shows the two forces acting on the electron during the time it is in the field

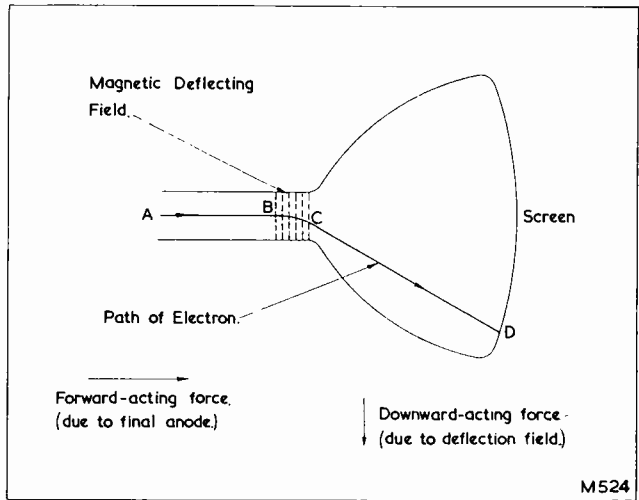

This will then ensure that electrons passing through at different points will still suffer the same amount of deflection and may consequently still strike the screen at the same point. If the deflecting field were not sufficiently regular the fault known as "deflection defocusing" becomes apparent. The usual symptom of deflection defocusing is poor focus at the edges of the scan.¹

The four-pole electromagnet shown in Fig. 36 (f) could be described as a *deflector coil assembly*.² Practical deflector coil

¹ Poor focus at the edges of the scan may also be caused by faults other than deflection defocusing.

² Other easily recognisable terms may be employed to describe this assembly, one frequently encountered being "deflection yoke."

field which would be given if a coil of wire were placed around the neck of a cathode ray tube. A current is passed through the coil, and this causes a magnetic field to be set up around it. It is assumed in Fig. 38 (a) that the coil is energised such that a South pole appears at its left hand side, whereupon lines of force whose direction is from North to South appear inside the neck of the tube.

When an electron travelling along the path ABCD of Fig. 38 (b) enters the magnetic field it encounters lines of force which are neither parallel nor perpendicular to its own line of travel and which become weaker as they approach the centre of the tube neck. An approximate idea of the field in which the electron finds itself is given in Fig. 38 (c),

which shows the situation existing on the section XY of Fig. 38 (b). (It is assumed, in Fig. 38 (c), that electrons travel towards the reader.) The lines of force *immediately*

the tube neck is illustrated by the shaded areas. The lines of force in the circle are not in the same plane as the paper and their lower ends are nearer the reader than are

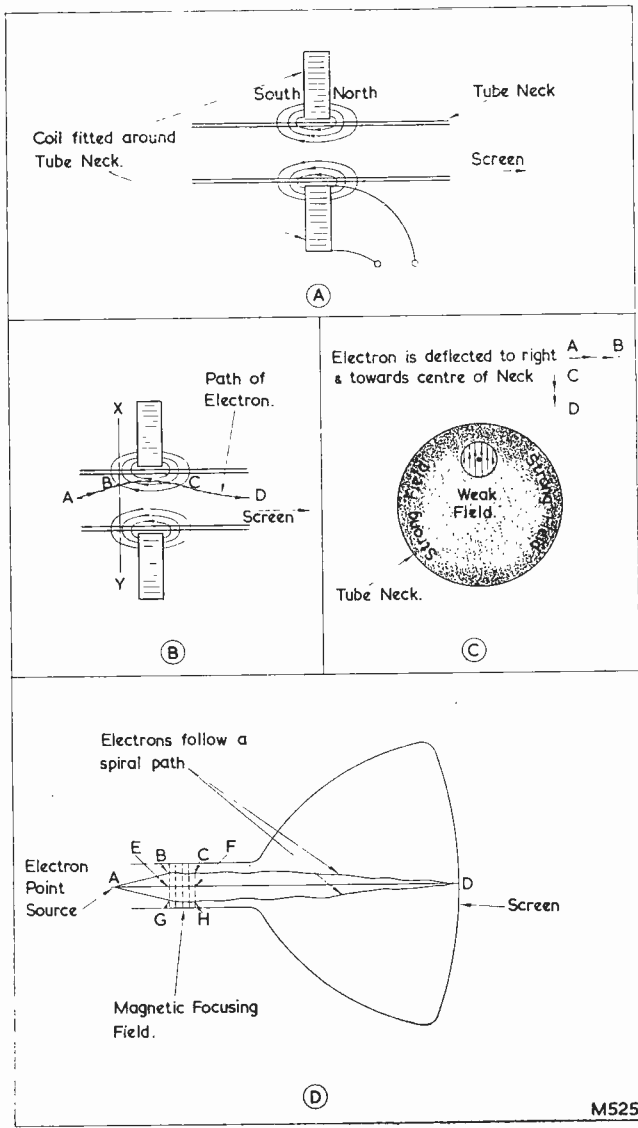

Fig. 38 (a). A coil fitted around the neck of a cathode ray tube can cause curved lines of force to appear inside the neck. (b) The path followed by an electron when travelling through the curved lines of force. (c) A presentation of the conditions existing in the cathode ray tube neck along section XY of (b). The shading indicates that the field is weakest at the centre of the tube neck. (d) When electrons are deflected inwards by a focusing magnetic field they assume a spiral path

around the electron of Fig. 38 (b) are those shown in the circle of Fig. 38 (c) whilst the fact that the field is weaker at the centre of

their higher ends. Despite this fact, the circled field immediately around the electron is still sufficiently similar (apart from its

upward direction) to that shown in Fig. 34 for the electron to suffer sideways deflection, this time towards the right. At the same time, we already know that a magnetic field always tends to deflect an electron in motion towards its weakest part. The result is that the electron of Fig. 38 (c) becomes subjected to two forces. One of these forces, indicated by the arrow AB, causes it to be deflected to the right, and the other, indicated by the arrow CD, causes it to be deflected towards the centre of the tube neck.³ The net result of these two forces is that the electron is not only deflected towards the centre of the tube neck (the desired effect) but that it is also deflected sideways. The combination of these two forces causes the electron, whilst travelling through the field, to assume a spiral path. After leaving the field it continues on this spiral path until it finally strikes the screen.

magnetic field, and suffer no deflection because they pass through a point of zero field strength. In consequence, they do not assume a spiral movement.

So far as the television design engineer is concerned, the usefulness of the magnetic focusing system is that it causes electrons to be deflected inwards, thereby allowing the focusing magnet (or electromagnet) to function as a lens. The fact that the magnetic field imparts a spiral motion to the electron is incidental, and can be ignored if the goodness of focus given by the magnetic system is not impaired thereby. In practice, magnetic focusing systems are capable of providing excellent results, and it is only their bulk and expense which nowadays makes them unattractive for commercial television receivers when compared with electrostatic focusing systems.

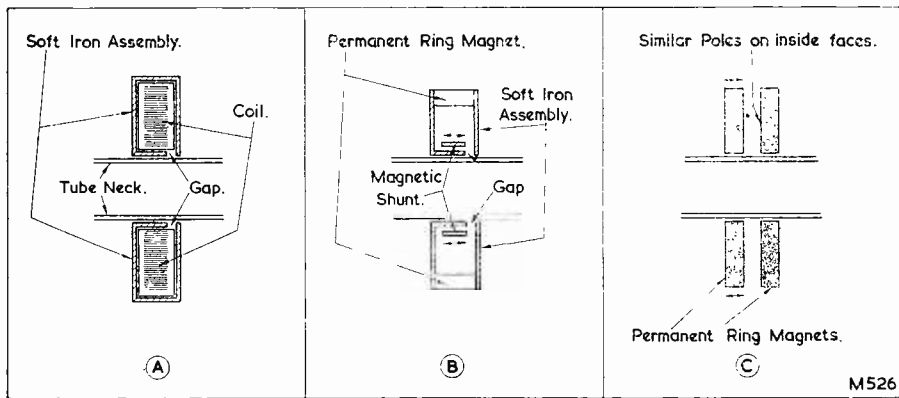

Fig. 39 (a) A practical focus coil. (b) A permanent magnet focusing assembly. The ring magnet is magnetised such that one pole appears on the right hand face and the other pole appears on the left hand face. (c) An alternative permanent magnet focusing assembly. In this case two ring magnets are employed, the distance between them being adjustable

The overall effect is illustrated in Fig. 38 (d) wherein the paths of several electrons are traced as they travel through the magnetic focusing field. Apart from electrons following line AEFD, all electrons are deflected inwards towards point D which should lie on the surface of the screen. Also, after leaving the magnetic field they all have a spiral movement. Electrons following path AEFD carry on in a straight line through the centre of the

In Fig. 38 (a) it was assumed that the focusing electromagnet was so connected to its source of supply that its left hand side became a South pole. In practice, the polarity of the focusing magnet, or electromagnet, does not matter.⁴ Reversing the polarity of the electromagnet of Fig. 38 (a) would not affect its ability to focus the beam, it would merely reverse the direction of the spiral traversed by the electrons before striking the screen.

Control of focus when using magnetic focusing systems may be obtained by varying

³ It is sometimes a little difficult to understand the reason for the inward-going deflection of the electron, this being due to the fact that, when it enters the focusing field, its path is in the same plane as the lines of force it encounters. However, after it has been initially deflected sideways, this condition does not exist and deflection inwards becomes possible.

⁴ Provided that its external stray field does not interfere with other magnetic fields controlling the electron beam, or that stray fields from other magnetic assemblies do not interfere with the focusing field.

the position of the magnet assembly, or electromagnet, along the neck of the tube, and/or by varying the strength of the field it provides. In many commercial receivers the position of the magnet on the tube neck is fixed (the optimum position having been found before the receiver went into production) whereupon the only adjustment of focus is given by variation of field strength.

Practical Magnet Assemblies

The simple coil shown in Fig. 38 (a) would be uneconomic in a practical television receiver, as an excessive amount of current would be required to enable it to provide a sufficiently strong field.

This difficulty is overcome in the arrangement shown in Fig. 39 (a). In this diagram the electromagnet coil is enclosed in a soft iron container which enables the field to be concentrated in a "gap" close to the tube neck. The electromagnetic arrangement illustrated in Fig. 39 (a) is very typical of the "focus coils" which were employed in domestic televisions some years ago. These focus coils have now been ousted by purely magnetic assemblies, which are dealt with later in this article.

Over the period when they were used, focus coils provided several advantages. One of these was that they enabled a fine degree of focus to be obtained by means of a simple potentiometer circuit which could vary the current flowing through the coil. Also, the potentiometer controlling focus could be mounted at any convenient point on the receiver chassis. The disadvantages of the focus coil were that they were wasteful of rectified h.t. power (which is always at a premium in a competitively priced receiver); that the resistance of the wire with which it was wound was liable to increase as it grew

warmer, thereby (unless special precautions were taken) causing reduction of energising current and the necessity of re-adjusting the focus control; and that, due to the large number of turns of copper wire needed for its manufacture, it was in itself an expensive item.

Whilst the disadvantages just outlined preclude the use of focus coils in current conventional domestic televisions, focus coils are still used in such specialised applications as projection receiver cathode ray tube assemblies and camera tube assemblies.

Fig. 39 (b) illustrates a cross-section through an early type of permanent magnet focusing unit. In this case the field is once more concentrated inside the neck of the tube by means of a soft iron assembly with a "gap". Control of the strength of the magnetic field is achieved by varying the position of a soft iron magnetic shunt close to the gap. When the magnetic shunt lies over the gap, most of the lines of force appearing at this point flow through it. When the magnetic shunt is moved away from the gap, a large proportion of the lines of force flow out into the neck of the tube.

More recent magnetic focusing assemblies employ two ring magnets positioned as shown in Fig. 39 (c). These two magnets have similar poles on their inside faces, with the result that opposing fields appear inside the neck of the cathode ray tube. Control of the composite focusing field obtained with this arrangement is obtained by varying the distance between the two magnets.

Next Month

In next month's article, we shall conclude our discussion of components which are employed in company with the cathode ray tube.

TWO-WAY RADIO IN SOUTH AFRICA

continued from page 865

central fire station in cases where "blind" spots restricted radio communication. Most of the vehicles fitted with radio apparatus, he said, used very high frequency, which had a limited line-of-sight range. All the apparatus had to be crystal controlled, to ensure that there was no deviation from the frequency allocated. The use of two-way radio was strictly controlled by the Department of Posts and Telegraphs, and it could be used only after the granting of a licence, costing £5 a unit a year, by the postal authorities.

In addition to four-wheeled vehicles and harbour craft, motor-cycles are now being fitted with two-way radio. The Cape Town fire brigade already has one of these, and the traffic department's motor-cycles are to be

fitted with sets for keeping in touch with the headquarters of the department.

With television still to be introduced in South Africa and the Federation of Rhodesia and Nyasaland, and the date of this still likely to be some years off, the demand for the ordinary types of radios is good, and models in a wide range of prices are prominent among the lines with which the furniture dealers gain steady turnover. In many cases the more expensive types of radios are imported in the partly finished condition—that is to say, the often elaborate cabinets are the products of South African factories. Gram-radios and similar combinations are also made up in this way in South Africa.

The TELETRON "COMPANION"

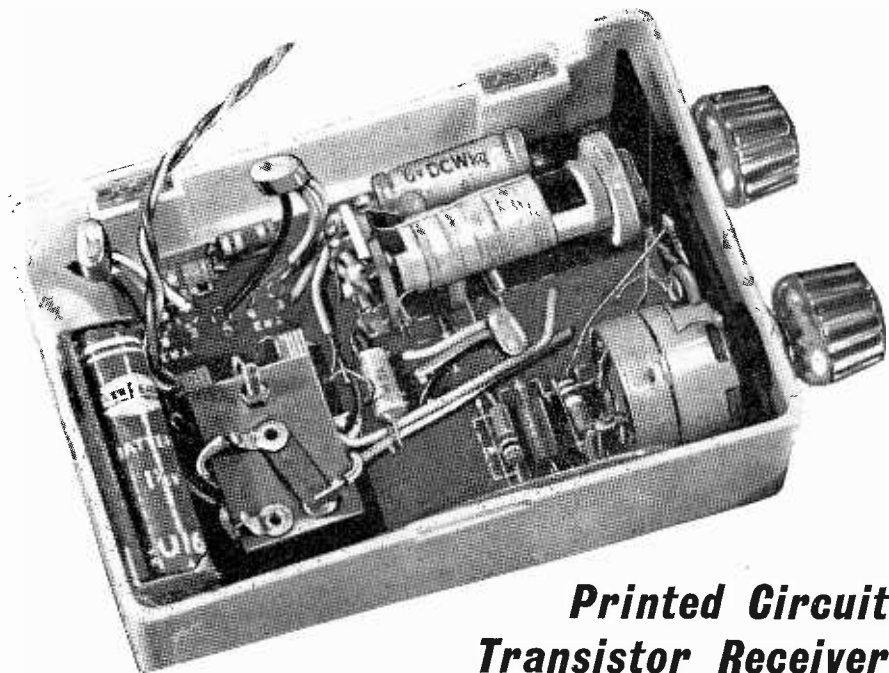

Printed Circuit Transistor Receiver

This article gives constructional details of a simple 3-transistor receiver which may be built in a relatively short space of time. The receiver employs a printed circuit, and a plastic cabinet is available

described by S. BENNETT

OVER THE PAST FEW YEARS AMATEUR constructors have been quick to take advantage of the many benefits provided by transistors. These are by now so well known that the writer does not need to devote any further space to them in this article. Another recent newcomer to the electronic scene, the printed circuit, has not, however, been utilised in home-constructor circles by any means as extensively. The reason for this state of affairs is mainly due to the fact that printed circuits are specialised items which lend themselves only to the particular piece of equipment for which they were originally designed. In practice, nevertheless, the printed circuit offers the amateur

such considerable advantages over conventional wiring that it is almost a pity that it has not been more frequently employed.

The receiver which is described in this article employs a printed circuit, with the result that a very compact layout may be achieved. Also, the constructor has the comforting feeling that his component and wiring positioning is almost inevitably bound to be closely similar to that employed in the prototype. The printed circuit used here (available, incidentally, from the Teletron Co. Ltd.) employs the especially useful device of marking all the major circuit points with suitable references, thereby obviating any doubts concerning the correct point to which

a particular component should connect. On the Teletron circuit board some considerable thought has gone into ensuring that all points are adequately identified, the upper (non-copper) side showing component outlines designated by their circuit references, and the lower side having circuit points denoted by numbers or letters printed in the copper itself. As a result of this care in design the risk of making incorrect connections becomes very small indeed.

The "heart" of the circuit is provided by the coil L_1 . This coil differs from the more conventional types employed on medium and long waves insofar that it is wound on a long former in which is fitted a similarly long internal dust-iron core. As such, the coil assembly becomes closely similar to a conventional ferrite frame aerial, and takes on the property of the latter of being able to pick up transmitted signals without the use of an external aerial. Also, due to the

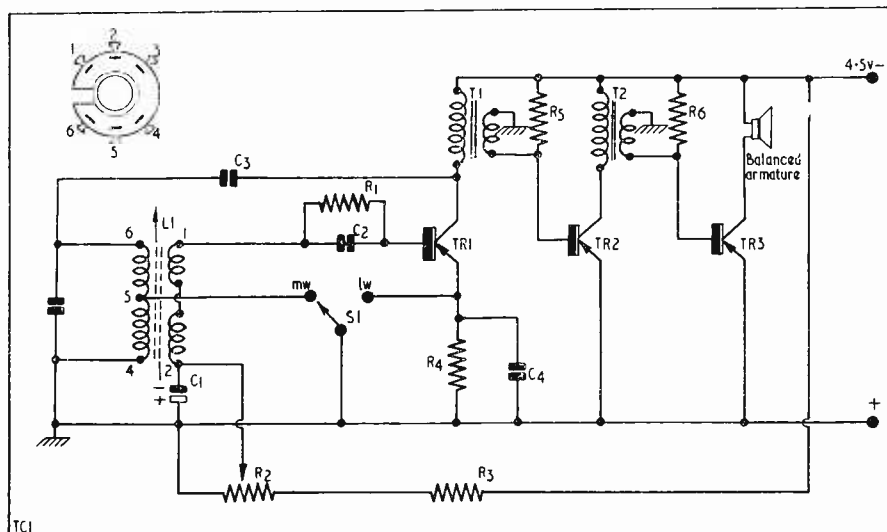

Fig. 1. The circuit of the "Companion" printed circuit receiver

Parts List

Condensers

- C_1 2 μ F electrolytic
- C_2 500 pF, miniature
- C_3 20 pF, miniature
- C_4 0.01 μ F, (Hunts type W99)

Resistors

All fixed resistors are $\frac{1}{8}$ watt

- R_1 2.2k Ω
- R_2 25k Ω , volume control with switch.
(Egen type 105)
- R_3 100k Ω
- R_4 100 Ω
- R_5 3.3k Ω
- R_6 4.7k Ω

Coils and Transformers

- L_1 Medium and long wave coil (Teletron type FX25)
- T_1 Transformer (Ardente type D240)
- T_2 Transformer (Ardente type D239)

Transistors

- TR_1 Mazda XA102 or Red/Yellow spot
- $TR_{2,3}$ Yellow/Green spot or equivalent

Miscellaneous

- 1 Wavechange switch (Teletron)
- 1 Printed circuit panel (Teletron)
- 3 1.5V batteries (Ever-Ready type U16, or Vidor type V.0036)
- 1 Cabinet (Teletron)
- 2 Knobs, $\frac{1}{4}$ in. spindle

The Circuit

The circuit of the "Companion" receiver is illustrated in Fig. 1, and some notes on its functioning may be of interest before constructional details are given.

proportionately large mass of the core, the coil has the desirable property of a high Q factor. A further feature of the coil is that its core is adjustable, thereby enabling a control of inductance to be achieved. In

consequence, it becomes possible to tune the receiver in which the coil is connected by means of the core adjustment, and there is no necessity to employ a variable tuning condenser at all.

In Fig. 1 the winding of L_1 which functions as the tuned circuit appears between terminals 4 and 6. The fixed condenser connected across these terminals provides the necessary tuning capacity, and is supplied as part of the coil assembly. For medium wave

The collector of TR_1 is connected to the primary of transformer T_1 , this component providing an a.f. coupling, with correct matching, to transistor TR_2 . The collector of TR_2 is, in its turn, coupled by transformer T_2 to the third transistor TR_3 . Both TR_2 and TR_3 function in the earthed emitter mode, and a.f. junction transistors are specified. The collector of TR_3 couples into a balanced-armature reproducer, this functioning as a "speaker" and having the added advantage

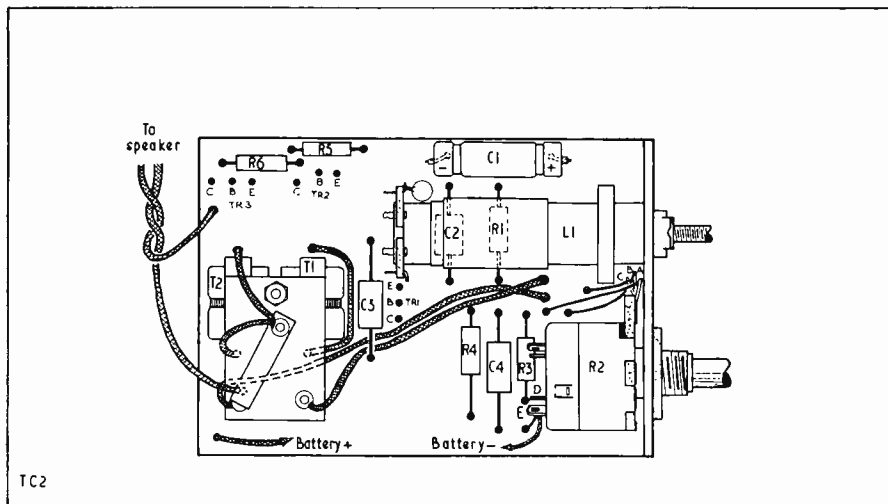

Fig. 2. Layout of the chassis

reception the wavechange switch S_1 connects terminal 5 to the earth line of the receiver, thereby short-circuiting the lower part of the winding. For long wave reception, the complete winding between terminals 4 and 6 remains in circuit. The winding between terminals 1 and 2 provides a low impedance coupling suitable for connection to transistor TR_1 . TR_1 functions as detector, as well as r.f. and a.f. amplifier, in much the same manner as does a triode valve employed in a regenerative detector stage. Detection is achieved by the effective diode provided between base and emitter, whilst a feedback voltage, for purposes of regeneration, is taken from the collector and applied, via C_3 , to the tuned circuit. Control of regeneration is obtained by means of the potentiometer R_2 , this varying the bias between base and emitter of TR_1 and, thus, its gain. R_2 carries out the dual function of reaction and volume control. An r.f. junction transistor is specified for the TR_1 position.

of requiring no output transformer.

Construction

As may be gathered, construction of the receiver is a relatively simple matter, and the few steps necessitated are described in full in the text which follows. It might be advantageous at this stage to point out to constructors who are unfamiliar with printed circuits the ease with which connections to the circuit board may be made.

As with all soldering processes, the main requirements are that the soldering iron should be clean and well-tinned, and that a reliable cored solder is employed. The circuit copper should tin without any trouble, and there is little point in keeping the iron on any joint after it has been reliably made.

The first components to be fitted are C_2 and R_1 . The marking on the upper surface of the board illustrates clearly the positions these components take up, and the holes through which their lead-out wires pass.

After these wires have been inserted in their holes they should be cut such that a small portion protrudes, and bent over so that they lay flat on the underside of the board. Where wires are bent over in this fashion it is advisable to do so in a direction which ensures that they remain on the copper conductor to which they connect. This will assist soldering and will obviate risks of "bridging" between conductors.

Coil L_1 comes next, this being fitted to the metal bracket eyeleted to the board in the manner illustrated in Fig. 2. The mounting hole for L_1 is notched to ensure that the latter is fitted with correct orientation. The potentiometer R_2 is next fitted, and its tags should take up the position illustrated in Fig. 2, i.e. volume control tags pointing towards L_1 . At this stage the locking nut for R_2 need not be tightened further than is needed to hold it in position during winding, as it will need to be removed later when the chassis is fitted into its cabinet.

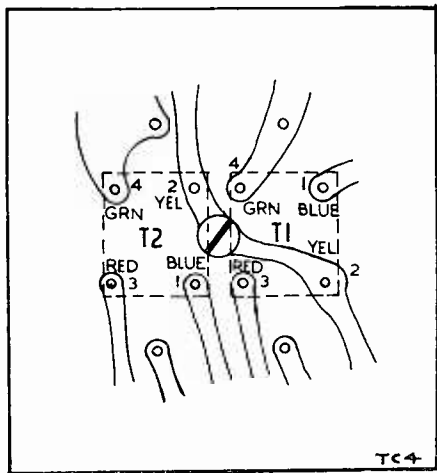

Fig. 3. Detail illustrating the print around transformers T_1 and T_2

L_1 is now wired into circuit. Fig. 1 illustrates the coil tag numbering, the view given in this diagram corresponding to the case where the core-adjusting screw is away from the reader. Tag No. 1 of the coil should be wired to circuit point 1 (indicated in the copper print) near the edge of the board. Tag No. 2 of the coil connects to the adjacent circuit point 2, tag No. 4 to circuit point 4, tag No. 5 to circuit point 5, and tag No. 6

to circuit point 6. All these connections should be made with tinned copper wire insulated with sleeving. Tag No. 3 of the coil is not connected into circuit. The circuit points 1, 2 and 4 just mentioned should not be confused with the similarly numbered points in the groups around transformers T_1 and T_2 which are illustrated in Fig. 3.

Transformers T_1 and T_2 are next mounted and wired in. Mounting is achieved by means of a 6-BA nut and bolt whose head, on the copper side of the board, is shown in Fig. 3. Secured under the 6-BA nut is the wavechange switch, S_1 , the panel of this switch helping to secure the transformers in position. Both Fig. 2 and the photograph of the chassis illustrate the method of assembly employed here. Fig. 3 shows the manner in which the transformer lead-out wires connect to the board and this diagram should be carefully followed. In order to ensure that no excessive strain is placed on the transformer lead-out wires these should be initially wound in the form of a spiral on a piece of 18 s.w.g. wire. When the 18 s.w.g. wire is removed the transformer lead-out wires will retain their spiral form, whereupon they may be lightly stretched, as required, to reach their appropriate circuit points.

The remaining resistors and condensers, C_1 , C_3 and C_4 , and R_3 to R_6 , may next be fitted to the board and soldered. As with C_2 and R_1 , the positions of these components are clearly indicated on the upper side of the board. It will be noted that the inner lead-out wire of R_3 connects to a small isolated section of the copper print. The remaining hole of this section takes a tinned copper wire connected to tag A of potentiometer R_2 (see Fig. 4), and it would prove helpful if both this wire and the lead-out from R_3 were soldered at the same time. The lead from the circuit point to tag A of the potentiometer should be insulated with sleeving.

The remaining tags of potentiometer R_2 may now be connected up. Again, tinned copper wire, with sleeving, is required. Consulting Fig. 4, tag B of the potentiometer should be connected to circuit point P (identified on the copper side of the board), and tag D (on the switch section) to the point designated "-4.5" on the copper side of the board. Tag C of the potentiometer connects to the earth line conductor, this being that in contact with the metal bracket. A hole close to the bracket accepts the connecting wire (see Fig. 2). Tag E connects to the negative tag of the battery holder; and sufficient lead length should be provided to enable the battery holder to be removed from the cabinet when changing batteries. The photograph of the chassis indicates the position taken up by the battery holder when the chassis is fitted in the cabinet.

Final Steps

The connections to the wavechange switch have next to be made. Reference should be made to Fig. 2 whilst wiring this component. The centre tag of the switch, that connecting to the arm, has two wires, insulated with sleeving, soldered to it. One of these wires passes through the hole immediately behind transformer T_2 , whilst the other passes through the hole immediately in front of T_2 and below the switch panel. These two leads are, of course, soldered to the circuit copper at the holes through which they pass. It will be noted that there are two holes having a disposition similar to those just mentioned immediately behind and immediately in front of transformer T_1 . The circuit copper at these two points should be linked by a short length of wire insulated with sleeving.

The underside of the board should next be examined and the two circuit points on either side of the reference "S1" located. The left hand tag of the wavechange switch, that immediately in front of transformer T_2 , connects to the "S1" circuit point which is nearer reference P. The remaining tag of the switch connects to the other "S1" circuit point, this being that nearer the letter S of "S1". Again, the wiring employed should be covered with sleeving.

The reproducer leads are next fitted, these connecting to the circuit points designated "O.P.". A positive battery lead is next required, this being connected to the earth conductor at the hole in the bottom left hand corner. (See Fig. 2.) This battery lead should be soldered to the positive tag of the battery holder, sufficient lead length being provided to enable the battery holder to be removed from the cabinet when changing batteries.

The transistors are the final components to be connected. There should be no necessity to shorten the transistor lead-out wires, and care should be taken to avoid excessive heat when soldering. It is advisable to insulate the lead-out wires with sleeving. The transistors may be positioned over the circuit points to which they connect, as shown in the photograph of the chassis.

The final process consists of connecting up the reproducer and of fitting the chassis in the cabinet. The latter may be carried out by primarily removing the bush-securing nut which was temporarily fitted to the potentiometer during wiring. A fibre spacing washer (or a spacing washer made of similar material) is next fitted over the bush, whereupon this is passed through the appropriate cabinet hole. The securing nut is then re-fitted and tightened up, thereby securing the potentiometer and the chassis. The final process consists of inserting the batteries in the battery holder, taking especial care to

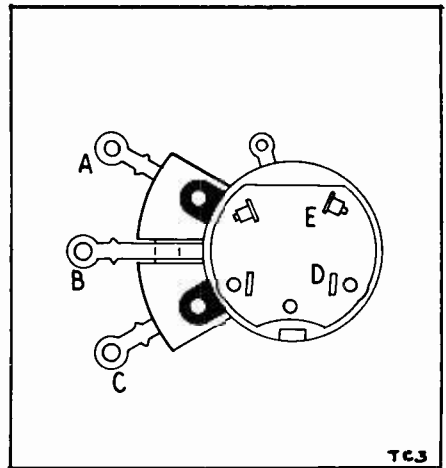

Fig. 4. The volume control, viewed from the rear. This diagram shows the tag references discussed in the text

obtain correct polarity, and of fitting the knobs. If necessary, the linking tags at the rear of the battery holder should be soldered over to provide good contact. A reducing bush is supplied with L_1 so that a normal $\frac{1}{4}$ in. knob may be used on the threaded spindle.

continued on page 910

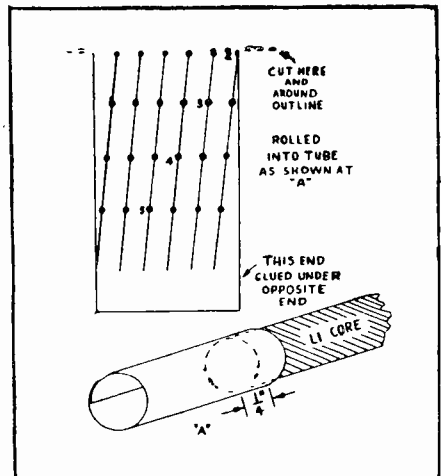
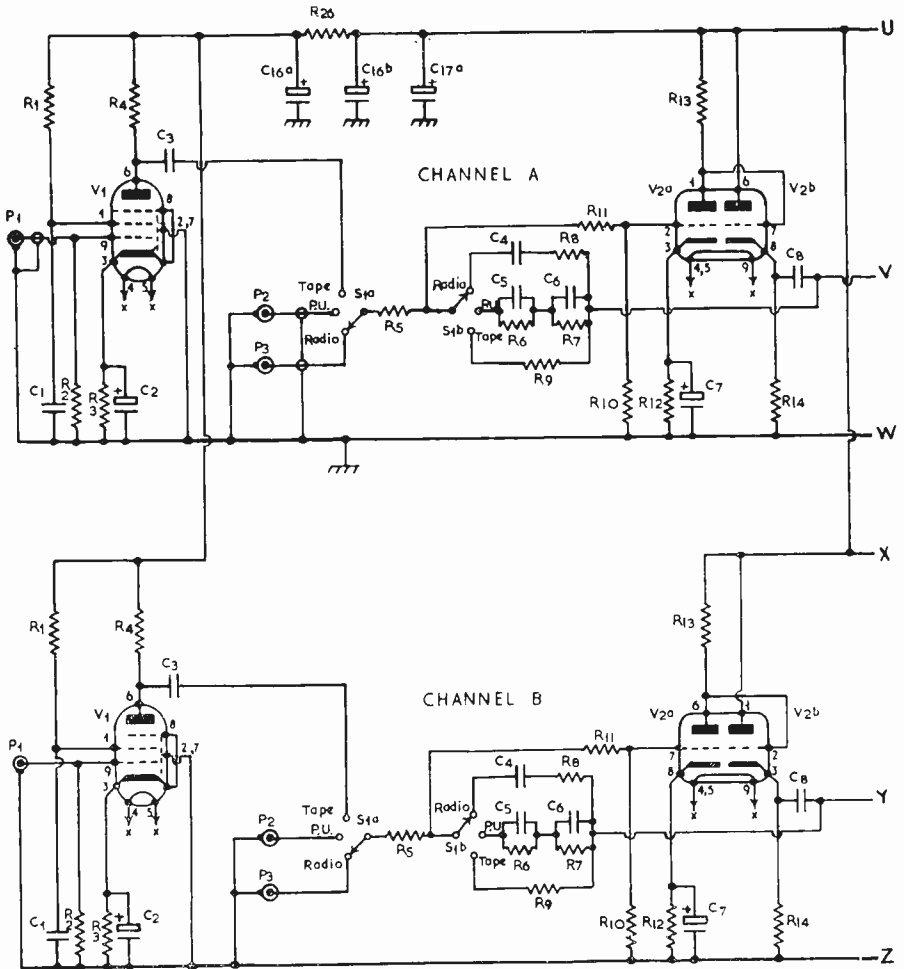

Fig. 5. The tuning scale

★ The JUPITER.

Stereo Pre-Amplifier

A Jason Design, by G. Blundell



The Pre-Amplifier Circuit

THE TONE CONTROL CIRCUIT IS THE ONE developed by P. J. Baxandall and published in *Wireless World*. The stage gain is low but the circuit works very effectively with linear controls and for simplicity has much to recommend it. Ganged potentiometers are used to allow simultaneous adjustment of both channels, and a separate balance control altering the gain of one channel allows adjustment of centring. The matching accuracy of the potentiometers should be quite close and 1.6dB or better is required. This is equally important on tone as well as volume controls.* Lack of balance

* These controls are now made by Morganite who have shown foresight in developing this type of control.

in the volume control would cause apparent position to alter when the volume level is altered, while variation in the tone control will cause a disembodied effect. It is important to have good frequency balance not only in the tone controls but also throughout the whole chain. Otherwise a frequency originating at one point, e.g. violin string, and its harmonics will appear to be nebulous; or alternatively the instrument will appear to move position according to the note played. Therefore it should be stressed again that the systems should be identical, and that also tweeters should be situated at the same point as the low frequency loudspeakers. In this respect the type of tweeter which seems best has a broad diffusion of sound, otherwise the "two loudspeaker" effect will be apparent.

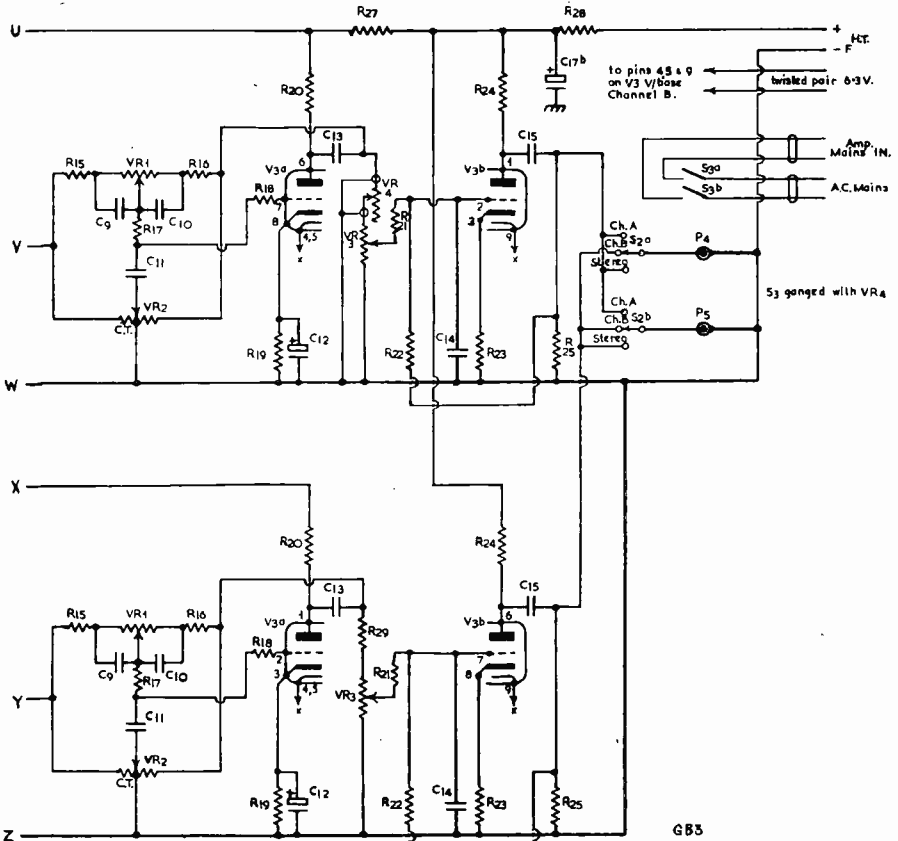

Fig. 5. Circuit of the Jupiter Pre-Amplifier

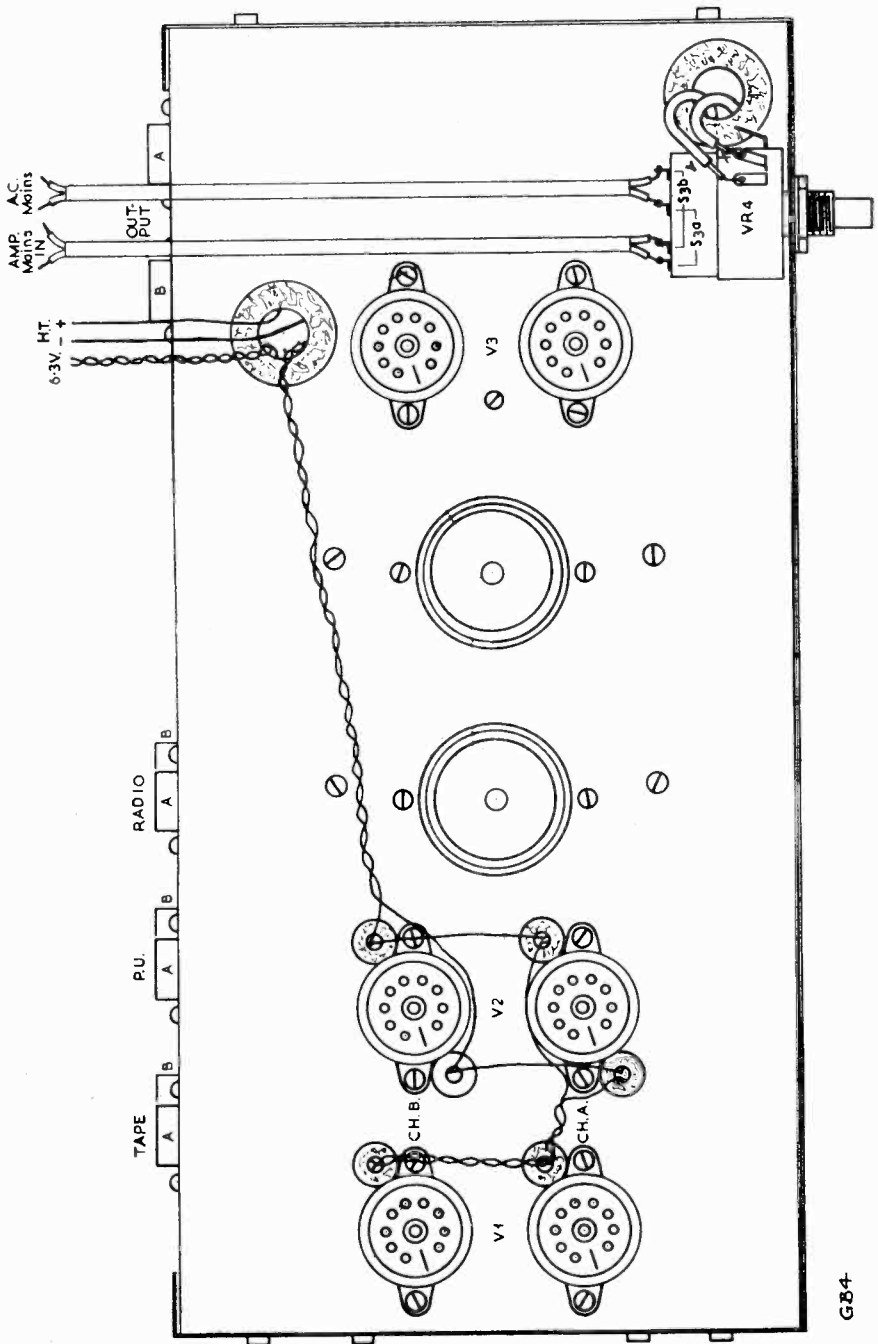

Fig. 6. Top-of-chassis diagram

G34

COMPONENTS LIST

One off R_1 to R_{25} required for each channel.

R_1	270k Ω H.S. 10%
R_2	1M Ω H.S. 10%
R_3	1.2k Ω H.S. 10%
R_4	100k Ω H.S. 10%
R_5	100k Ω H.S. 10%
R_6	10M Ω carbon 10%
R_7	470k Ω H.S. 10%
R_8	220k Ω H.S. 10%
R_9	100k Ω H.S. 10%
R_{10}	1M Ω H.S. 10%
R_{11}	1k Ω carbon 20%
R_{12}	1.2k Ω H.S. 10%
R_{13}	100k Ω H.S. 10%
R_{14}	47k Ω H.S. 10%
R_{15}	100k Ω H.S. 10%
R_{16}	100k Ω H.S. 10%
R_{17}	470k Ω H.S. 10%
R_{18}	1k Ω carbon 20%
R_{19}	1.2k Ω H.S. 10%
R_{20}	100k Ω H.S. 10%
R_{21}	100k Ω H.S. 10%
R_{22}	1M Ω H.S. 10%
R_{23}	1.2k Ω H.S. 10%
R_{24}	100k Ω H.S. 10%
R_{25}	220k Ω H.S. 10%

One each of the following components is required, these being common to both channels.

R_{26}	10k Ω H.S. 10%
R_{27}	10k Ω H.S. 10%
R_{28}	10k Ω H.S. 10%
R_{29}	100k Ω H.S. 10%
VR_1	1M Ω +1M Ω linear Morganite bass control

VR_2	500k Ω +500k Ω c.t. linear Morganite treble control
VR_3	250k Ω +250k Ω log. Morganite volume control
VR_4	250k Ω with switch Morganite balance

One off C_1 to C_{15} for each channel

C_1	0.25 μ F 300V wkg
C_2	100 μ F 6V wkg
C_3	0.05 μ F 300V wkg
C_4	500pF \pm 10%
C_5	500pF \pm 10%
C_6	150pF \pm 10%
C_7	100 μ F 6V wkg
C_8	0.05 μ F 300V wkg
C_9	0.005 μ F \pm 10%
C_{10}	0.005 μ F \pm 10%
C_{11}	100pF \pm 10%
C_{12}	100 μ F 6V wkg
C_{13}	0.05 μ F 300V wkg
C_{14}	200pF
C_{15}	0.005 μ F 300V wkg

One each of the following components is required, these being common to both channels.

C_{16a}	16 μ F 450V wkg
C_{16b}	16 μ F 450V wkg
C_{17a}	16 μ F 450V wkg
C_{17b}	16 μ F 450V wkg
Two sets of valves required.	
V_1	Mullard EF86
V_2	Mullard ECC81
V_3	Mullard ECC81

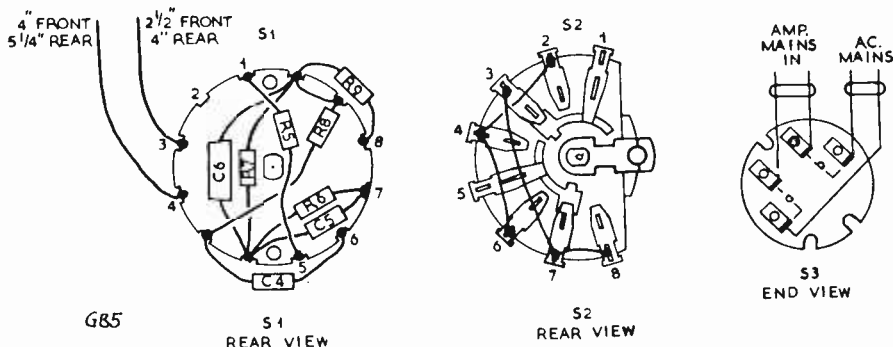
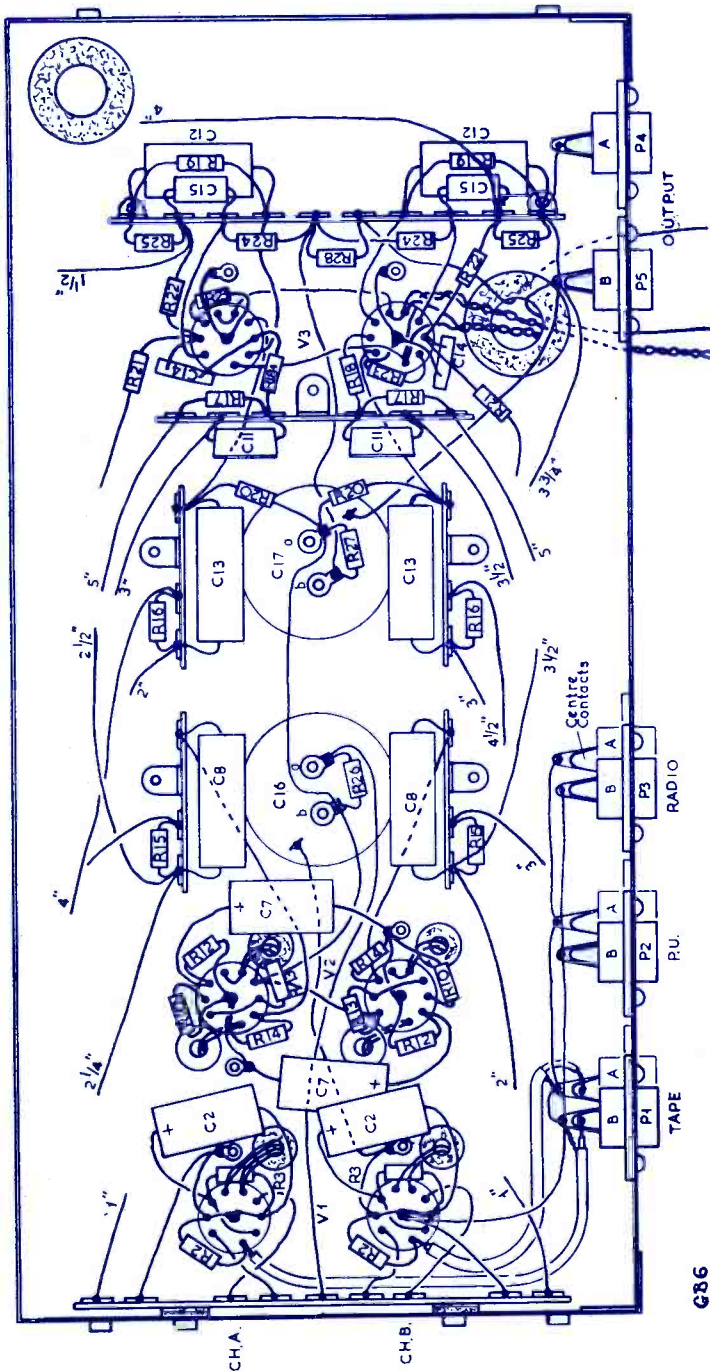

Fig. 7. Diagram of switch wiring



G86

Fig. 8. Stage 1 point-to-point wiring

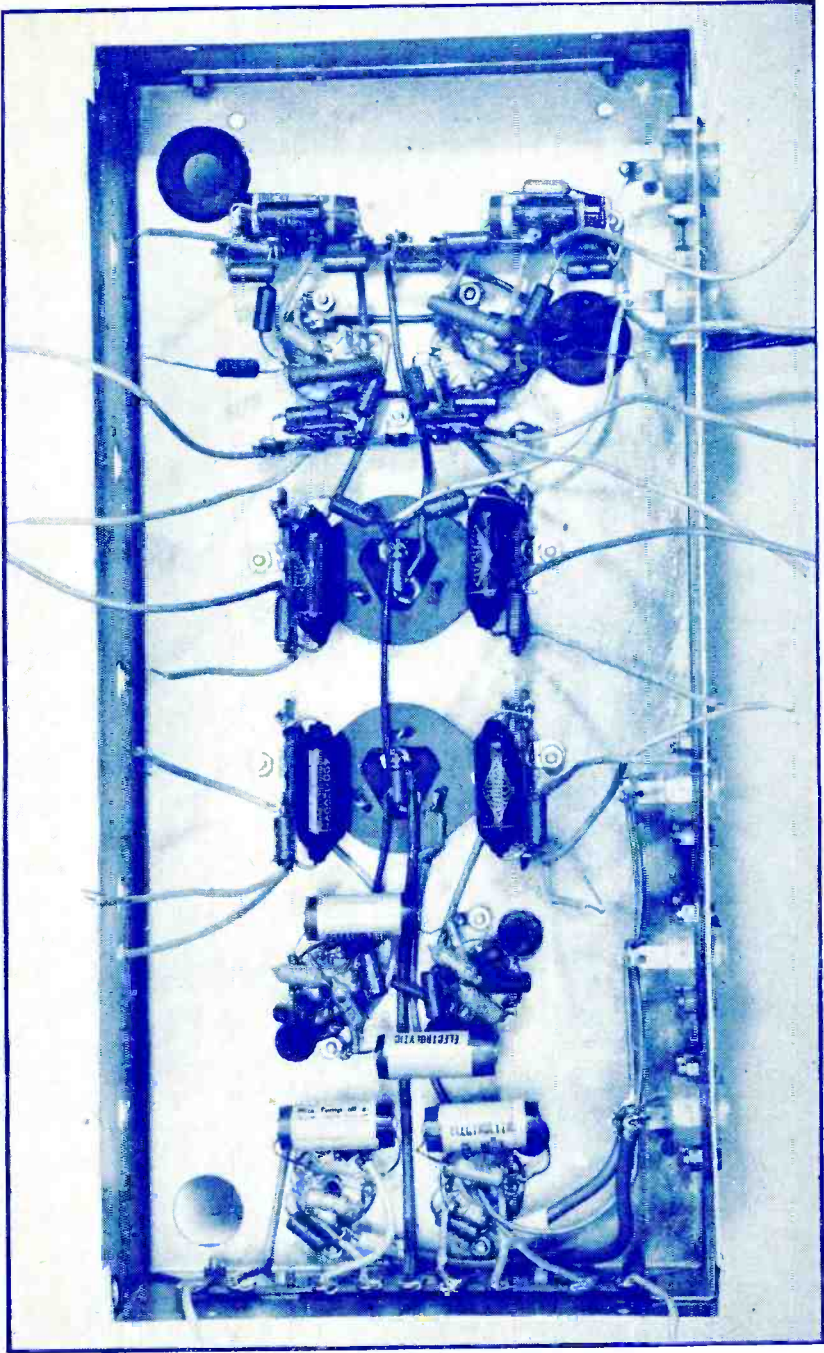
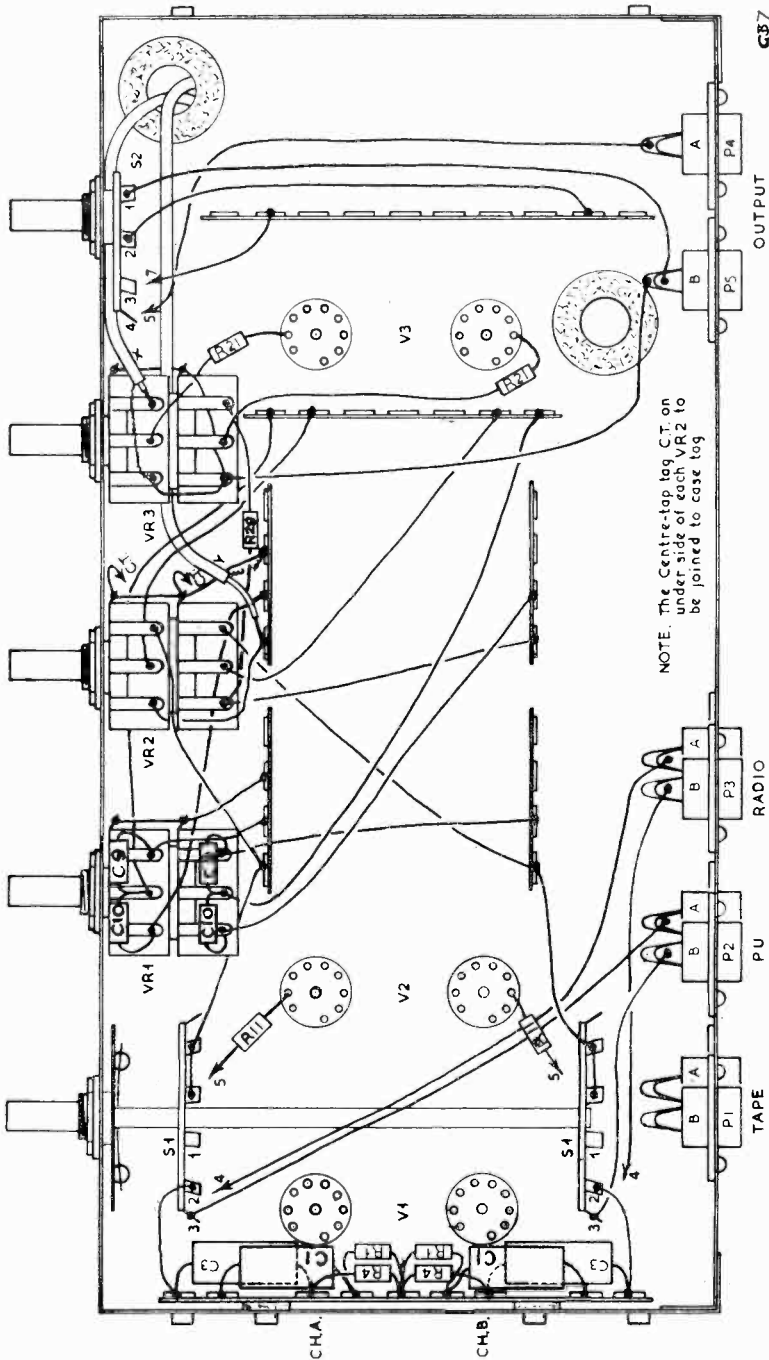

Fig. 9. Stage 1 paint-to-point wiring—compare with Fig. 8



CB7

Fig. 10. Stage 2 point-to-point wiring

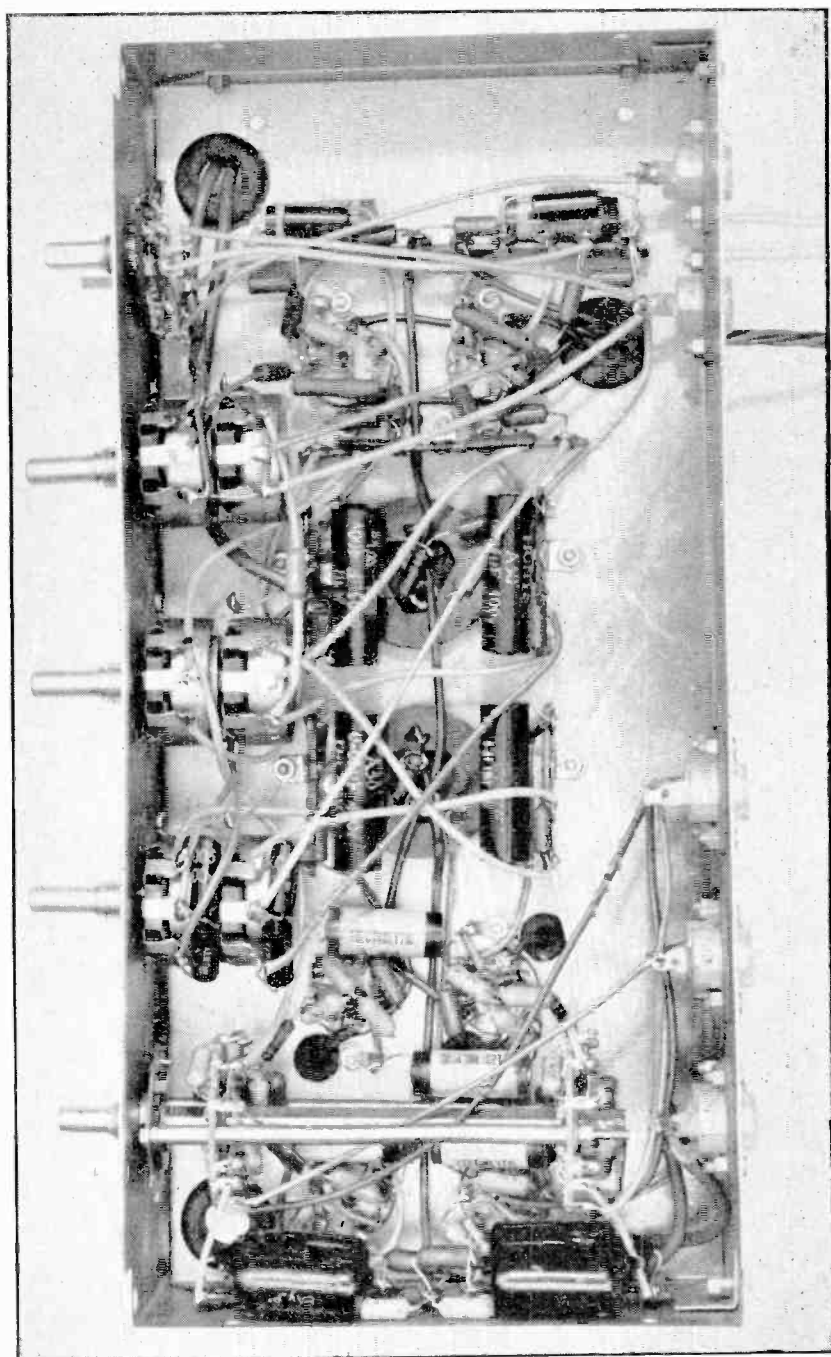

Fig. 11. Stage 2 point-to-point wiring—compare with Fig. 10

Sensitivity

Radio 0.5 volt for 1 volt output at
1000 c/s
P.U. 50 mV for 1 volt output at
1000 c/s
Tape 2mV for 1 volt output at
1000 c/s

Tone Control

Treble +16dB at 10 kc/s
-17dB
Bass +10dB at 100 c/s
-10dB
+13dB at 50 c/s
-16dB

Rumble filter

50 cycles 0dB
20 cycles -3dB
15 cycles -6dB
10 cycles -13dB
5 cycles -27dB

At the same time this diffusion of sound must not be obtained by reflection from walls or again the apparent source will be dependent on the accidents of sound reflection and therefore on the frequency.

The Baxandall tone control circuit is fed from a cathode follower, and the same point may be used to feed a tape record unit, using the first stage of the pre-amplifier to correct the signal; for example, when making a tape recording from a gramophone record.

Around the last stage is built a rumble filter. As its name suggests, the primary object of this stage is to attenuate very low frequencies which may be generated from the gramophone motor. When using crystal pick-ups this circuit is even more essential. A further object of this circuit is to prevent low frequencies, which may be recorded, from entering the main amplifier and causing overload at inaudible low frequencies. For example, the amplifier is only capable of delivering one watt of power at 10 cycles, therefore a signal of only 1/10 normal can cause overload and, even though itself inaudible, will cause anything being reproduced at the same time to also suffer overload.

The second stage uses normal frequency correcting methods in the form of feedback networks. One position only is provided for gramophone correction, and the same position may be used for 78 records. The difference between the responses required is only a few dB and most of this can be corrected on the tone control circuits.

The first stage may be omitted, and the sensitivity of the unit is then sufficient to use with the usual crystal stereo pick-ups, such as Ronette, Acos, etc. If a variable reluctance pick-up is to be used, then the tape pre-amplifier may be connected to the pick-up

channel; details of this will be supplied in a later article. The unit will then be suitable for such pick-ups as the Decca, Goldring and Tannoy, which have outputs between 3 and 7 millivolts. The first stage as shown on the unit is intended as a tape pre-amplifier and the equalizing on the second stage is set to suit pre-recorded tapes which are made to C.C.I.R. standards (100 microsecond time constant). This stage is a straightforward low noise amplifier using an EF86, but particular care must be taken with the wiring of this stage and the layout diagram should be followed exactly if hum troubles are to be avoided. High stability resistors must be used where specified, this point being important in achieving a low background noise.

The gain of one channel is made variable to compensate for differences in the two chains, whether it be difference actually recorded on the record or in the pick-up or amplifier or in the sensitivity of the loudspeakers. The balance control may be set at first using a single channel record and adjusted so that the resultant sound appears to come from a point halfway between the speakers. If this cannot be achieved, reverse the connections of one speaker and balance should then be possible.

The channel switch allows the unit to be operated as a single channel amplifier connecting both the main amplifiers to either pre-amplifier channel, and the whole unit then operates as a single 20-watt amplifier. This switch is also useful when checking the system, since either channel can be listened to separately and any defects noted.

Compatibility of Records

It cannot be emphasised too strongly that many standard single channel pick-ups will cause damage to stereo records because the vertical stiffness of the pick-up movement is too great and permanent damage will be caused to the records. The opposite, however, is satisfactory, and a stereo pick-up can be used to play normal L.P. records.

Construction of the Unit

Note that the electrolytic condensers are mounted on spacers approximately $\frac{3}{8}$ in long in order to reduce the overall height of the unit; and the cans should not touch the chassis, the earthing being wired separately to the appropriate points in the circuit.

Firstly, mount the valveholders and complete the wiring to chassis. Inspect the joints to solder tags carefully, particularly if a small iron is used to make the joints. The heater wiring may then be completed, this being taken over the top of the chassis to achieve some electrostatic shielding. The wires

should be twisted to give magnetic cancellation of the 50 cycle field.

As can be seen from the point-to-point drawing and photograph, the majority of the wiring can be completed before the mechanical assembly of the frame with the potentiometers is commenced. The lead lengths are given allowing this stage to be completed as far as possible. The switch wiring should then be completed as in the drawings and carefully inspected. It is a good plan to arrange all the resistors so that the value can be read in order to make for ease of inspection. As a result of using these resistors, the writer is now wholeheartedly in favour of colour coding instead of writing as a means of marking resistors, since it is otherwise so difficult to find a mistake quickly.

The unit may easily be tested operationally on all channels, but even if all appears to be functioning correctly, the voltages in the circuit should be checked. The figures given in the table were obtained from a 1,000 ohm per volt instrument, but even if any other sensitivity is used it can be seen that all the triodes should measure the same within 10%. If variations are found, inspect the values of the anode and cathode resistors. If a condenser is suspect, this may be disconnected and the voltage measured in its absence. The

Voltage Measurement Table

<i>V supply 275</i>			
	<i>Pin No.</i>	<i>Pin No.</i>	
	<i>Channel A</i>	<i>Channel B</i>	<i>Voltage</i>
V ₃ k ₂	3	8	1.1
V ₃ a ₂	1	6	95
C ₁₇ B	—	—	215
V ₃ k ₁	8	3	0.9
V ₃ a ₁	6	1	75
C ₁₆ B	—	—	170
V ₂ k ₂	8	3	85
V ₂ A ₁	1	6	84
V ₂ k ₁	3	8	1
C ₁₆ A	—	—	150
V ₁ g ₂	1	1	72
V ₁ a	6	6	45
V ₁ k	3	3	1.3

most likely faults are in fact wiring faults, and as there are two channels the performance can be compared.

Note that the treble control has a centre tap and this should be wired to the earth screen of the potentiometer; as this is underneath the potentiometer, the wiring is not very clear in the second stage point-to-point drawing and photograph.

The JASON MOTOR AND ELECTRONIC COMPANY

An associate company has now been formed in France known as "Jason (France)" 19 Boulevard des Capucines, Paris, 2e.

The object of the company is to manufacture high fidelity equipment in France, and the first products to be launched are the Jason J10 amplifier and the C.Q. speaker which is being made under licence from C.Q. Audio Ltd.

TRANSISTOR RADIO COSTS REDUCED

The cost of transistor portable radios can now be reduced as a result of a step taken by Newmarket Transistors. Five matched complements designed to give good overall performance are being offered. Now, the mass production of transistorised receivers can follow the pattern already established for valve-operated sets.

The usual coding has been dropped and the five lines are colour coded for different numbers of transistors and circuit arrangements. Each transistor carries a number, identifying its position in the receiver. The transistor complements are offered complete with diode at very competitive prices. Production quantities are immediately available.

TELEVISION SOCIETY PREMIUMS

The Television Society has awarded the following Premiums, for outstanding papers read before the London meetings in 1956/57:

The WIRELESS WORLD Premium to DR. D. GABOR, F.R.S. (Imperial College) for his paper on "A New Picture Tube."

The MERVYN Premium to DR. E. L. C. WHITE, M.A. (E.M.I. Research Dept.), for his paper on "Alternatives to the N.T.S.C. Colour System."

The MULLARD Premium to MR. S. N. F. DOHERTY, B.S.C., and MR. P. L. MOTHERSOLE (Mullard Research Labs.) for their paper on "Automatic Gain Control Circuits in Television Receivers."

The E.M.I. Premium to DR. J. A. SAXTON, M.I.E.E. (D.S.I.R. Radio Research Station) for his paper on "Scatter Propagation and its Application to Television."

The ELECTRONIC ENGINEERING Premium to DR. R. PEARCE, B.S.C., A.M.I.E.E. (E.M.I. Research Dept.) for his paper on "The Return of Electrostatic Focusing."

The PYE Premium to MR. IAN ATKINS (Senior Dramatic Producer, B.B.C. Television) for his paper on "Studio Production Techniques."

The CRY BABY Alarm

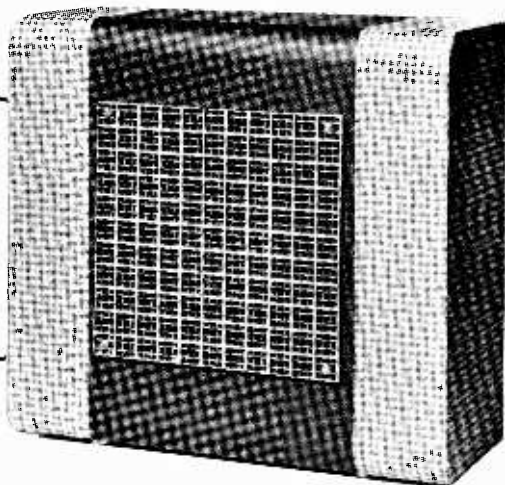

described by **E. GOVIER**

DESIGNS FOR BABY ALARMS ARE NOT IN themselves over-numerous, but where they exist an examination of the circuitry will reveal to the radio hobbyist that such units are little more than simple audio amplifiers. As such, with the usual microphone input and speaker output, etc., they are by the nature of their design liable to reproduce in an amplified form any audio input over a fairly wide frequency range. In essence this is unnecessary where the baby alarm is to be used purely as such, most noises from the nursery consisting of high-pitched audio cries emanating from the vocal chords of the young genus homo-sapiens. (Who amongst us is not only well aware of this but has also taken his turn at "sentry-go" in the small hours?)

Ordinarily, baby alarm circuits are designed as multi-purpose units, in addition to their primary function also serving as audio amplifiers, audio signal tracers and as receiver test "back-ends", etc. The components necessary to achieve this end are more numerous and expensive than would otherwise be the case where the unit is designed primarily as a baby alarm only. In the circuit about to be described, both of the above considerations have been borne in mind. Designed simply as a baby alarm only, with no unnecessary frills, the components required for completion, and therefore the total cost, have been kept to a minimum consistent with a high level of efficiency, safety and reliability.

The unit has been specially designed to emphasise any high pitched audio sounds, therefore cries, etc., are amplified more than those of the unlikely low register sounds. A balanced armature earpiece is used both for the microphone and the speaker. The alarm is intended for use on a.c. mains and for this purpose utilises a double-wound mains transformer, thus completely isolating the chassis from the mains supply. This ensures that no possible harm will be caused to the infant should it possibly open the microphone unit or disconnect the connecting wires.

Circuit

This is shown in Fig. 1 from which it will be noted that two valves, an SP61 (VR65) and an EL32 (CV1052), plus a contact cooled rectifier having a rating of 250V at 50mA, are used. A volume control (R_3) is combined with the a.c. mains on/off switch, it being merely necessary to adjust this to the required audio level when in operation. The input is via T_1 , the microphone matching transformer, the secondary of which is fed into the grid of the first amplifying stage (SP61). The small cathode bias required for this stage is supplied via R_1 decoupled by C_1 . Voltage for the screen grid is taken from the following output stage cathode, this being in the order of some eight volts. Using this method of screen supply, a considerable saving is effected by the elimination of the usual voltage drop resistor and bypass condenser.

The resultant output from this first stage is fed, via C_2 and R_3 , into the grid of the output valve. The balanced armature earpiece, connected into the anode circuit, functions as the speaker unit. The power supply section is conventional.

Assembly

The aluminium chassis and combined panel is supplied completely pre-punched, and all that is required of the home constructor is to firmly and securely mount into position the main components before wiring the actual circuit.

The best method of assembly is to first mount the two valveholders and the three earthed solder tags, two with V_1 and one with V_2 ; these are fitted under the securing

screws as shown in Fig. 2. The two valveholders are of differing types, and to ensure that correct positioning is obtained, check each holder with the actual valve before securing. Next, fix the volume control R_3 to the rear chassis wall, and the microphone input sockets likewise. The transformer T_1 should now be mounted in position together with the associated tag-strips (see Fig. 2).

Following the above, the capacitor unit C_4/C_5 should now be secured to the chassis. This unit is of the prong fixing type and it should be secured by bending over the three tags so that they clamp tightly to the underside of the chassis. An alternative method of achieving the same object is to twist these tags slightly with a pair of pliers. At a later stage, these tags should be soldered to the

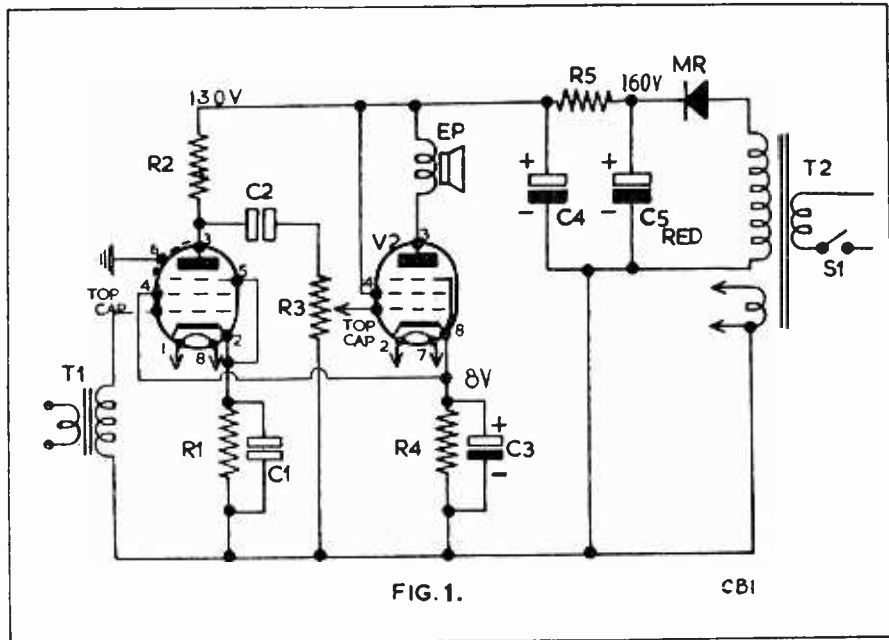

FIG. 1.

CBI

Circuit of the "Cry-Baby"

Resistors

Resistor	Value	Power	Colour Code
R_1	5.6kΩ	¼W	Green, blue, red
R_2	1MΩ	¼W	Brown, black, green
R_3	250kΩ	potentiometer	
R_4	680Ω	¼W	Blue, grey, brown
R_5	2.2kΩ	½W	Red, red, red

Condensers

C_1	0.1μF, 350V	wkg.
C_2	100pF, mica,	350V wkg.
C_3	25μF, 25V	wkg. electrolytic
C_4/C_5	32+32μF, 250V	wkg. electrolytic

- T_1 Mic. Matching Transformer (Clyne Radio Ltd.)
- T_2 Mains Transformer 200V at 20mA, 6.3V at 1A (Clyne Radio Ltd.)
- V_1 SP61 (VR65)
- V_2 EL32 (CV1052)
- Speaker—Balanced Armature Unit
- MR—Contact Cooled Metal Rectifier type E250/C50 250V at 50mA
- Chassis (Pre-punched) (Clyne Radio Ltd.)
- Cabinet (Clyne Radio Ltd.)
- Valveholders, one I.O. and one M.O.

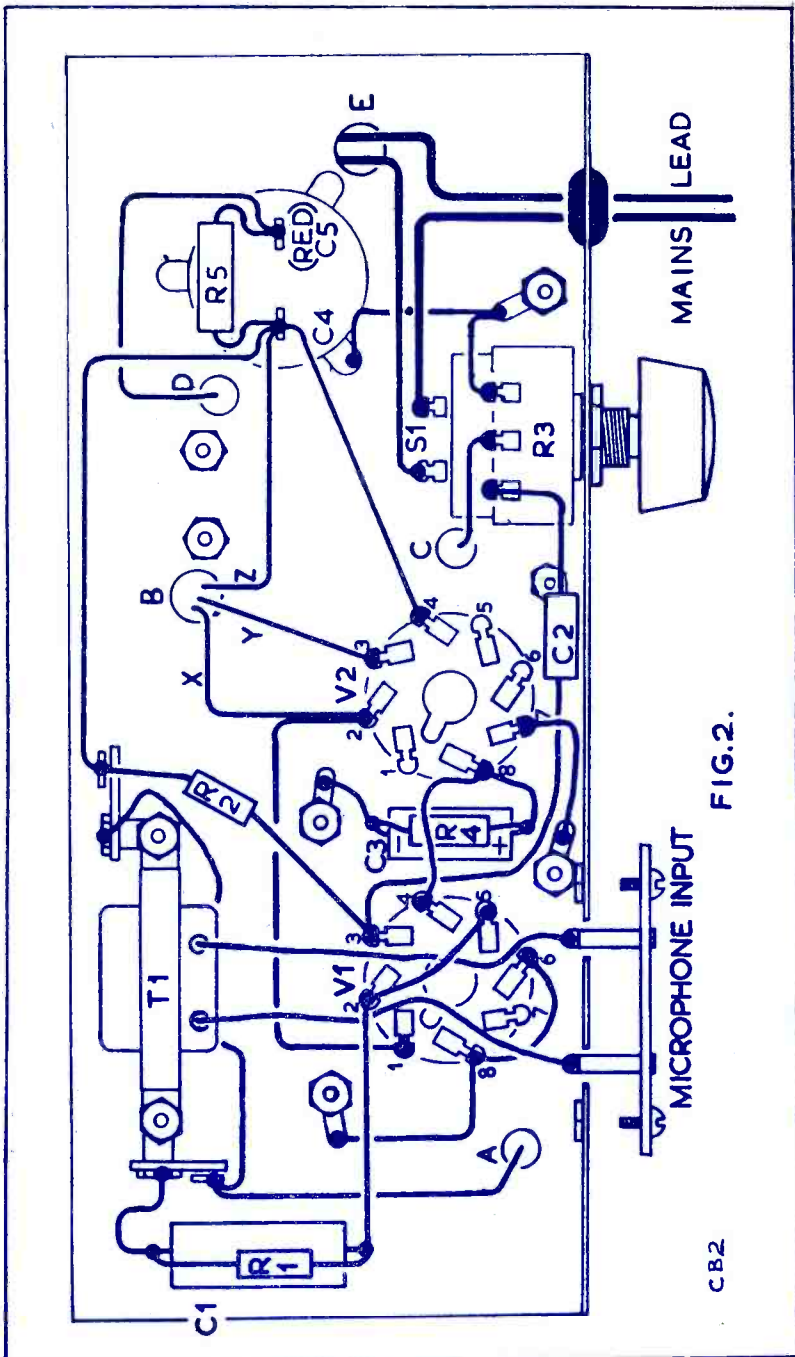
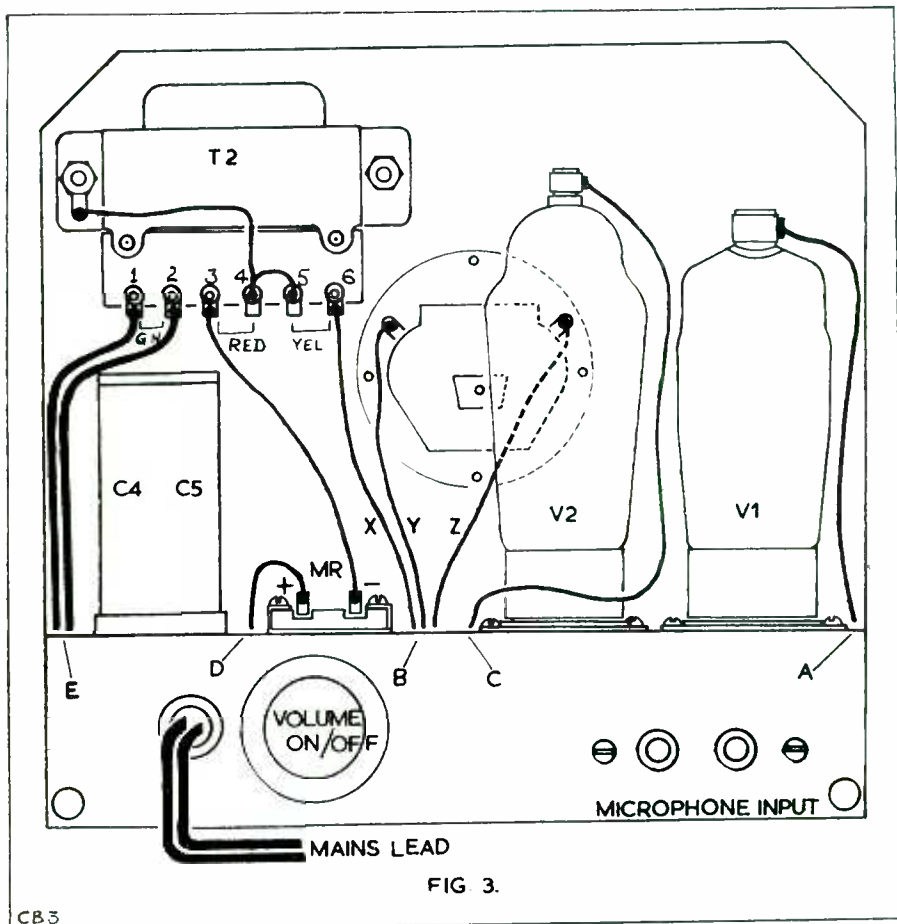

FIG.2.

C.B.2

Under-chassis point-to-point wiring



Above-chassis wiring

chassis both in order to achieve a good electrical earth return and to finally fix the capacitor in a secure manner.

The metal rectifier must next be firmly bolted to the chassis, this being followed by the mains transformer T_2 and the speaker unit—the latter two components being secured to the front panel. Note here that the speaker unit is secured by means of two small screws, each threading into the unit from the front of the panel. The remaining two diaphragm screws *should not* be disturbed, being used only for locating purposes.

The rubber grommet should now be fitted in position on the rear wall of the chassis.

Wiring the Circuit

Wiring the circuit is best carried out by firstly completing the power and heater supplies and secondly by including the remainder of the components.

Pass the mains input leads through the rubber grommet, soldering one wire to the switch S_1 , contained on the rear of the volume control. Pass the other wire through hole E and solder to the left hand green tag of the mains transformer. (See Figs. 2 and 3.) It should be noted here that one of the mains wires will have to be cut somewhat shorter than the other in order to fulfil the above instructions. From the remaining tag of the switch S_1 , connect a length of p.v.c. wire to the green 2 tag of the mains transformer,

first passing this wire through the hole E.

From tag red 3 of the mains transformer, solder a short length of wire to the minus (-) tag of the contact cooled metal rectifier. From the plus (+) tag of the rectifier, solder a length of p.v.c. wire to connect to the red tag of C_5 , first passing this wire through the hole D. (See Fig. 2.)

Connect, by means of a suitable length of p.v.c. wire, the mains transformer tag yellow 6 to pin 2 of V_2 valveholder, first passing this lead (X) through the chassis aperture marked B. From pin 2 of V_2 , take a small length of wire to pin 1 of V_1 .

Using a short length of bare wire, join together pins 6 and 8 of V_1 , ensuring that this wire does not touch any other valveholder tags, and solder the appropriate end of this bare wire to the solder tag as shown in Fig. 2. Connect pin 7 of V_2 to chassis by soldering a short length of bare wire to the nearest solder tag.

Returning to the mains transformer, join together red tag 4 and yellow tag 5, connecting these tags to chassis by soldering a length of wire to that earthed tag fitted to the panel with the transformer itself.

From the positive of condenser C_4 , solder two lengths of wire to connect with pin 4 of V_2 , and the free tag of the nearest tag-strip mounted with T_1 . Between the tags of C_4 and C_5 , connect the resistor R_5 . Dealing with the speaker unit, it will be noted that there are four solder tags contained on this—only two of which are used. In order to indicate the correct pair of tags, the unit is supplied with the two lead wires already soldered to these tags. The right hand lead (Z) (see Fig. 3) should pass through the aperture B and be connected to the positive solder tag of C_4 . The remaining speaker lead (Y) should pass through the aperture B and should now be soldered to pin 3 of V_2 .

Proceed to complete the wiring of V_1 as follows: Solder together pins 2 and 5 of the valveholder. To pin 2, solder one end of C_1 , the other end of which is connected to the earthed tag of the tag-strip. Across C_1 , connect the resistor R_1 . To pin 3 solder one

end of both C_2 and R_2 , the other end of the former being connected to the nearest tag of the volume control and that of the latter to the appropriate tag of the tag-strip as shown in Fig. 2. Connect together pin 4 of V_1 to pin 8 of V_2 . Solder the lower left hand wire of T_1 to the free tag of the tag-strip mounted at the left of the transformer and from this same tag, connect a length of p.v.c. wire to the larger of the valve top cap clips, first passing this wire through the aperture marked A in Fig. 3. Solder the lower right hand wire of T_1 to the earthed tag of the tag-strip mounted on the right of T_1 . The upper left hand wire of T_1 should now be soldered to the left hand input strip tag and the remaining wire of T_1 to the other tag of the same strip.

From pin 8 of V_2 , solder the positive (+) end of C_3 , the other end of this being now connected to that earthed solder tag mounted with V_2 valveholder. Across C_3 should now be soldered the resistor R_4 .

The right hand tag of R_3 should now be soldered to the earth tag mounted on the chassis near this component. From this same earthed tag, a short length of wire should now be soldered to one of the fixing clips of C_4/C_5 . To the centre tag of R_3 connect one end of a length of p.v.c. wire and, passing this through the aperture marked C in Fig. 2, solder the other end to the remaining valve cap clip (Fig. 3).

This completes the wiring of the baby alarm. The next step is to connect the respective valve grid clips, having inserted the valves, connect the microphone, plug into the mains, switch on and test the unit. Provided the above instructions have been carried out, with frequent references to the diagrams shown herewith, no trouble should be experienced in getting the alarm to work immediately.

It now remains to insert the completed unit into the attractive red and grey cabinet supplied. The chassis assembly is held in position by two wood screws, these also holding the bottom of the cabinet back in position. Two wood screws also hold the top of the cabinet back in position.

RADIO AMATEURS' COURSE

For several years a highly successful class for radio amateurs has been held at the Brentford Evening Institute. Brief details are as follows:

Classes: Radio Amateurs for P.M.G.'s Licence.

Radio Servicing, including TV.

Time: 7 p.m. to 9 p.m., commencing 22nd September.

Place: Brentford Evening Institute.

Further particulars may be obtained from the Borough Education Officer, Town Hall, Chiswick, W.4.

HI-GAIN BAND III PRE-AMPLIFIER

This new reprint (RR8) now available—1/2d. post paid

THE Mini- Meter

A Frequency Meter for the Beginner

By JAMES S. KENT

Part 2

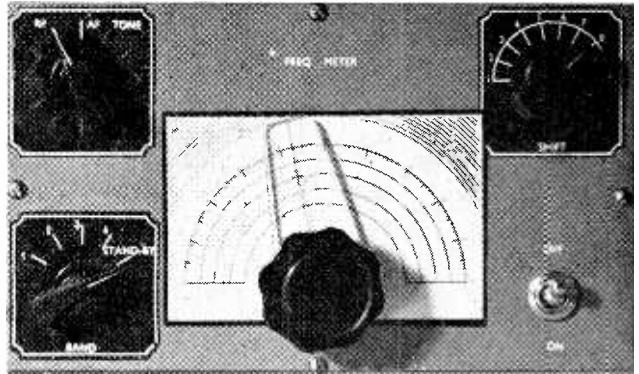

LAST MONTH THE CIRCUIT OF THE FREQUENCY meter was discussed, and in this issue the constructional method is dealt with in some detail. The description is arranged in logical sequence so that the beginner may read each paragraph and, following this, carry out the work so described in the correct order.

Drilling the Panel and Chassis

It is assumed that the reader has the few simple tools necessary for the purpose, these being a hand drill, centre punch, hand brace, three drills, $\frac{1}{8}$ in., $\frac{1}{16}$ in., $\frac{7}{64}$ in., and a small vice if available. The first item to be dealt with is the front panel.

(1) With the panel face uppermost on the bench, carefully measure and centre punch the painted surface to the dimensions shown in Fig. 2. If using a different variable condenser from that specified, allow for the possibly differing fixing screw holes. Next, drill through the panel at each centre punch mark using the $\frac{1}{8}$ in. drill. Following this, using the brace fitted with the $\frac{7}{64}$ in. drill, bore through holes A, B, C, D and E, first fixing the panel in a vice. (Note: When fixing in the vice, protect the painted surface by using a thick piece of paper or card within the actual vice jaws; blotting paper is ideal for this purpose.) The remaining holes, F, G, H and I, are left at $\frac{1}{8}$ in. diameter as first drilled.

(2) The next task is to drill the chassis front drop. This may be simply done by using the front panel as a template, allowing for the $\frac{1}{8}$ in. overlap of the panel at each end,

and centre punching the holes B, C and D, taking care that the true centres are marked. Also, the variable condenser fixing screw holes should also be marked in this manner. This completed, drill first with the $\frac{1}{8}$ in. and then the $\frac{7}{64}$ in. drill. The panel and the chassis drop apertures should now coincide. Fig. 3 shows both the chassis front and rear drop, the holes on the former being designated B, C and D to coincide with those on the front panel. The rear drop drilling details are clear enough, holes J and K being similarly treated as those for the front drop. The remaining holes are left at $\frac{1}{8}$ in. clearance.

(3) The chassis deck is next dealt with by following the details of Fig. 4. All holes are of $\frac{1}{8}$ in. diameter, except L which is to accommodate the valveholder, and M which is $\frac{1}{4}$ in. diameter (mains input to transformer). The actual diameter of L is $\frac{3}{16}$ in. and, if possible, the beginner should obtain an Osborn chassis cutter of this size for the purpose. The purchase of this useful tool is a worthwhile investment as it will save hours of hard work drilling and filing valveholder apertures. Failing this, holes may be drilled around a diameter of $\frac{3}{16}$ in. and an "Abra-File" used to complete the work.

(4) Having completed the foregoing, the cabinet lid is next treated by drilling three $\frac{1}{8}$ in. holes as shown in Fig. 5. These are for ventilation purposes and are necessary to ensure stability of the oscillator, in that the small amount of heat generated may easily be dispersed.

This completes the drilling details except for holes F, G, H and I of Fig. 1, insofar as

matching these to the actual cabinet front flanges are concerned. This, however, may be done at a later stage once the chassis is fixed to the panel. (See below.)

(5) In the following sequence, all the main components have to be mounted in their respective positions. Commencing with the front panel and chassis, fix to B (Fig. 2) the two-pole six-way Yaxley switch; and to D the single-pole single-throw switch. These two will hold the chassis and panel together while the remaining Yaxley is fitted to A and the small variable condenser to E. Next, position and secure the main variable

mounted, should have a free space in which to rotate—see under-chassis illustrations, where it will be noted that the condenser is mounted sideways, i.e. top nearest the coils.

(6) The valveholder should now be screwed into position, first ascertaining that the earthing tag is fitted under one nut and that the orientation of the holder is correct. (See point-to-point wiring diagram, Fig. 6.) Next, the tag-strip, output socket—with earth tag fitted, intervalve transformer, coils and mains transformer (with earthing tag fitted above chassis), should be screwed into position. From Fig. 6 take particular note

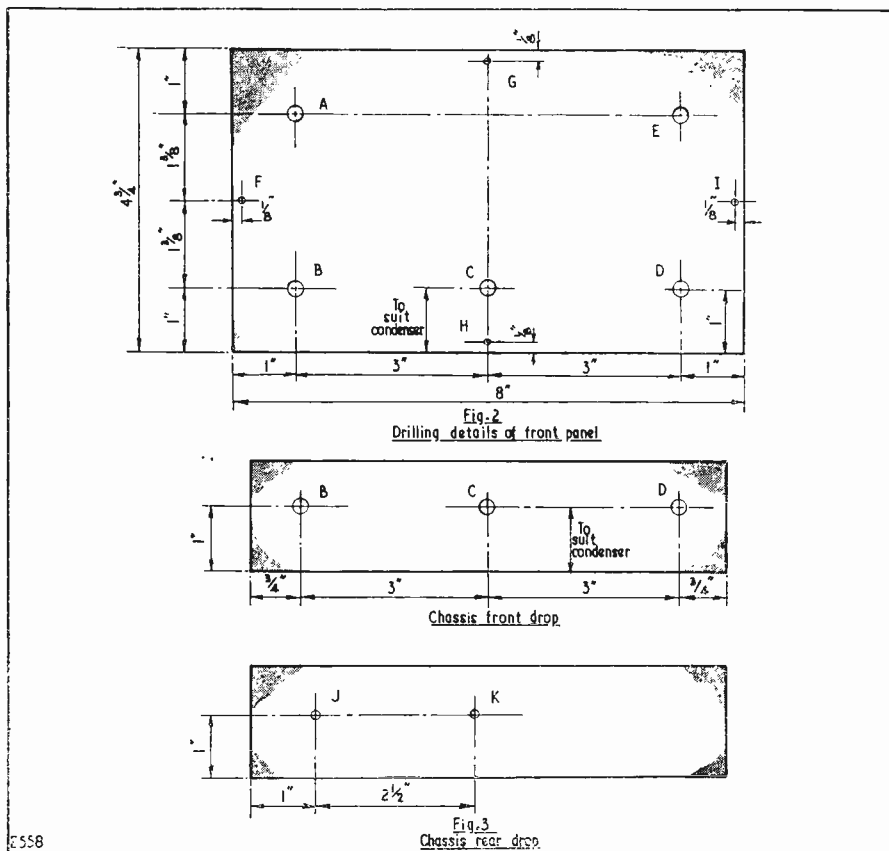

condenser. (Note: The holes for this will, of course, have to be drilled according to the type and make of component). As many types are available, drilling details of this have not been given. The main point to note is that the moving vanes, once the component is

of how these have been mounted in the prototype.

We have now completed the drilling and mounting of the main components. Following this, we continue with the actual wiring details.

Wiring Details

Commence by wiring the valveholder and allied components in the following sequence.

Valve tags 7, 8 and the centre metal lug should be joined with a length of bare tinned copper wire and soldered, one end of the wire being soldered to the valveholder earthed tag.

Tag 1 should be joined to tag 6 of the mains transformer via a length of PVC wire, this being taken through the chassis aperture previously drilled.

To tag 2 of the valveholder, solder one end of both R_3 and C_4 , the other end of the former being fixed to tag 2 of the paxolin tag-strip and the other end of C_4 to tag 3, from where a short length of wire is soldered direct to the output socket.

To tag 3 of the valveholder solder one end of R_1 , C_3 and R_2 . The other end of R_1 is then joined to tag 1 of the tag-strip; C_3 to the main tuning condenser tag and R_2 to tag 6 of the valveholder.

C_6 should now be taken from tag 4 of the intervalve transformer to chassis by soldering the earthy end to the earth tag mounted with the output socket. Tag 3 of the intervalve transformer should also now be joined to the same earth tag. Tag 2 of the same transformer should then be soldered to tag 2 of the paxolin strip (the h.t. + line) via R_5 .

Tag 4 of the valveholder should now be joined to SW_2 (see Fig. 7). To the main tuning condenser tag, solder a length of wire, the other end of which should be joined to C_2 . From the same tag of C_1 , solder a length of wire to SW_1 (see Fig. 7).

The mains input lead should now be brought through a rubber grommet, which should be mounted on the chassis backdrop, through the small rubber grommet on the chassis deck, and then soldered to tags 1 and 2 of the mains transformer; one lead to each tag, of course. At a point near the on/off switch (SW_4), cut one lead only. Bare the

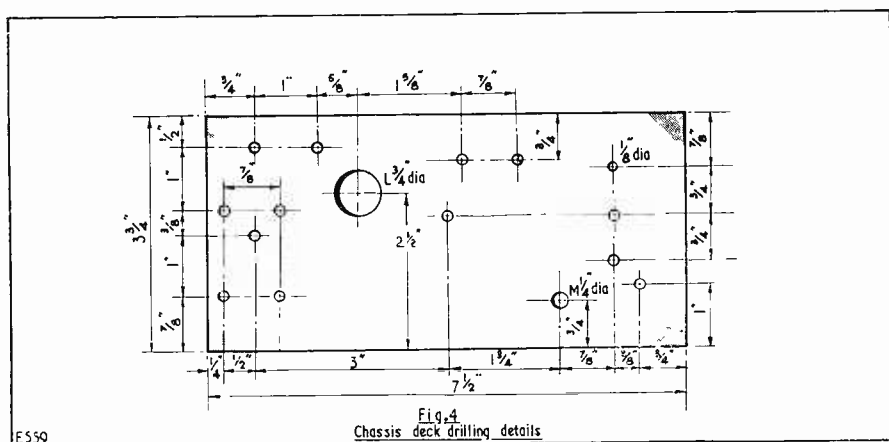

Join tag 5 of the valveholder to tag 1 of the intervalve transformer.

To tag 6 of the valveholder solder one end of R_6 , the other end of which is taken to tag 1 of the paxolin strip. To the same valve tag solder one end of C_5 , the other end of which goes to tag 5 of the intervalve transformer. (Note: In the prototype, one section of the tuning condenser has been removed in order to position C_5 . This is not, however, strictly necessary: C_5 could be sited along the rear of the component if so desired.) Next, join tag 5 of the intervalve transformer to SW_3 (see Fig. 7). Solder one side of SW_3 to chassis.

severed ends and solder to the switch, one lead to each tag of the switch.

Except for the coils, this completes the under-chassis wiring and we now continue with the above-chassis details, leaving the coils till last.

Tags 1, 2 and 6 of the mains transformer are already wired, leaving the remainder to be dealt with as follows:

With a short length of bare tinned wire, join tags 4 and 5 to the earthed tag of the small variable condenser. (See illustrations.) Ensure that this wire does not come into contact with any other tag of the mains transformer other than those stated.

Tag 3 of the transformer now remains to be connected into circuit. To the rear upright portion of the tag solder one tag of the RMO metal rectifier (*NOT* the red-painted tag). The rectifier itself must be so fixed to the tag that it is positioned on its side but *NOT* touching any other tag or metal part of the transformer. If the rectifier were to be mounted upright, the unit, when completed, would not fit into the metal cabinet.

The two electrolytic condensers C_7 and C_8 should now be soldered to the earthed tag on the mains transformer fixing bolt. Take particular care that the negative connections to these condensers are the ones soldered to the earthed tag. With the condensers

through the chassis and fix the other end to tag 2 of the paxolin strip mounted on the back drop of the chassis.

This completes the above chassis wiring, and we now continue to wire into circuit the coils.

Close attention to the following and frequent reference to Fig. 7 will ensure that this is done correctly. Fig. 7 shows both the Yaxley switch tags and connections and the coil tag ring positions.

All the No. 1 tags of the coils should be joined to earth via a single length of bare wire, taking care that this does not touch any other coil connection. Next, wire SW_1 as shown in Fig. 7, this being a rear view of the

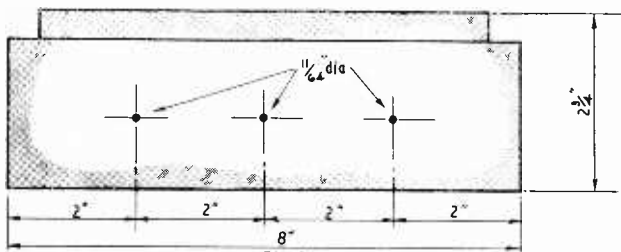

Fig. 5
Cabinet lid details

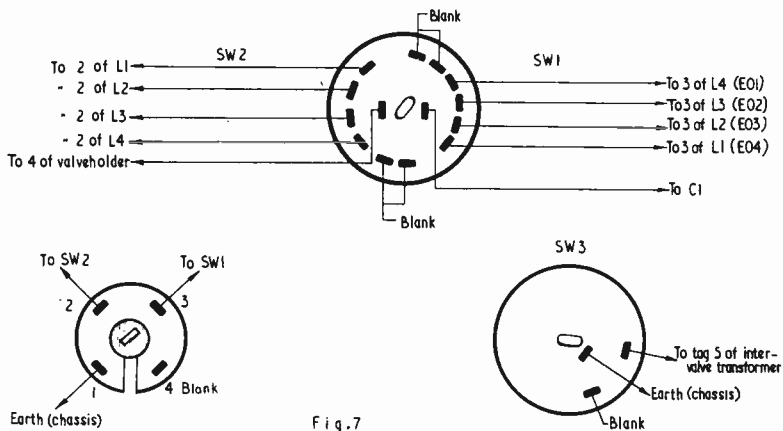

Fig. 7
Coil & switch details

E560

mounted upright and close together (see photographs), join the two positive ends via R_6 . Join the positive tag of the metal rectifier (coloured RED) to the positive connection of the condenser nearest the front panel (C_8). To the positive end of C_7 solder a length of PVC wire, and take this wire

Yaxley switch. Follow this by wiring SW_2 exactly as shown. The numbered tag connections of the coils are shown and it should be noted that tag 4 is left blank. All wires should be as short and direct as possible, using PVC wire throughout.

The connections to SW_3 are clearly shown.

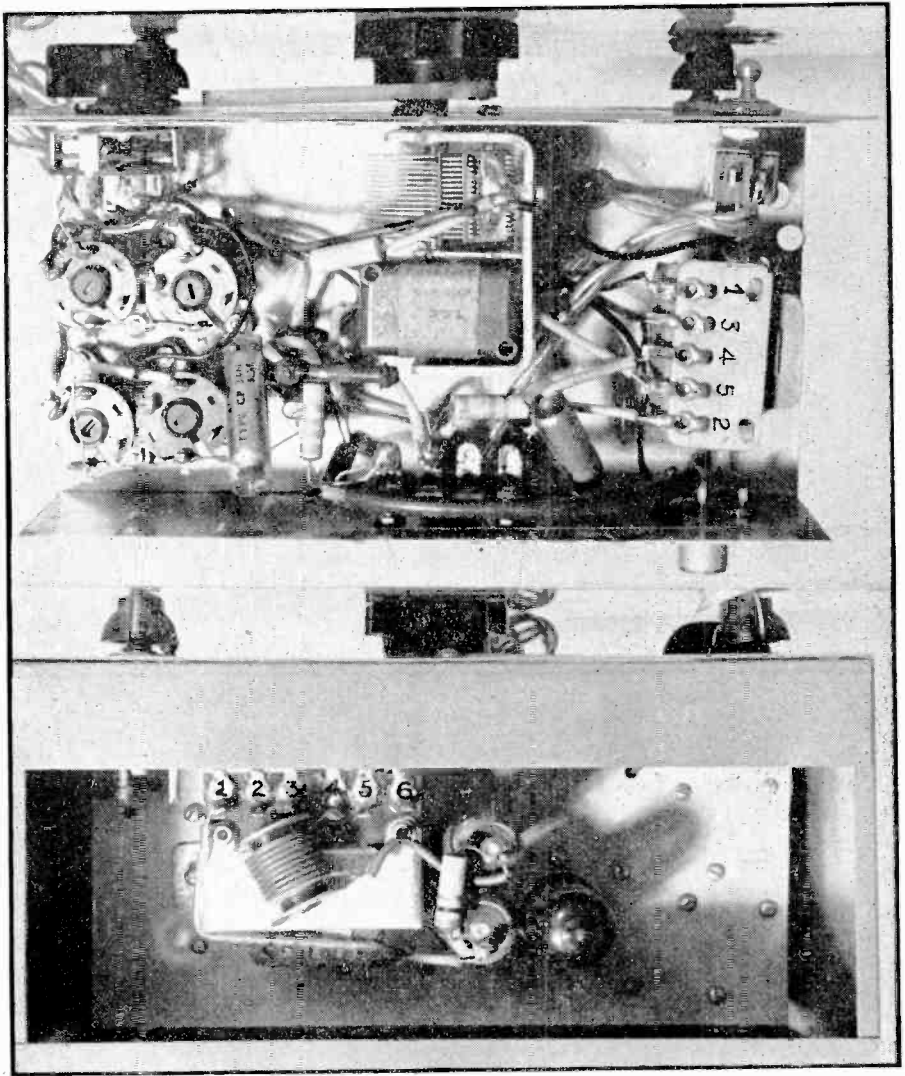

Fig. 6. Above, the underneath view of chassis; and below, view looking down on top

One point worth mentioning, however, is that the earth connection should be made to the switch metalling itself in order to avoid a long earth wire.

The unit is now completely wired, and the next step is to test the voltages before placing the valve into position. The following approximate voltages should be obtained:

h.t.+ output (junction R₅ and R₆) 165V;
tag 1 of intervalve transformer, 142V. With the valve in position and the audio modulator switched off, the h.t.+ output should read 140V; with the modulator on it should be 135V.

Next month we will deal with the calibration of the unit.

SOME YEARS AGO WHEN A NUMBER OF points dealing with t.v. problems occupied the attention of this column, a reader with obvious anti-t.v. leanings bitterly complained it ought to be re-named "T.V. Miscellany." In recent months the gramophone and records have been taking up an increasing amount of space. I hope no reader feels so strongly about it that he, in his turn, will suggest re-christening it "Gramo. Miscellany." It is odd how often when this column picks up a topic it seems to become "news" a month or two later. Since we started it, disc reproduction has attracted more and more attention. Even the B.B.C. had a special Radio Record week and ran a Gramophone Supplement in the *Radio Times*.

The great revival of interest in the gramophone is due to the extremely high level reached by modern pick-ups, amplifiers and recordings. This, together with impending developments in two-dimensional recording, has brought to light a very extensive interest among our readers, particularly in technical developments. With regard to dual recordings (in the same groove) to produce stereophonic effects, I think I made it clear that the leading manufacturers did not intend to market them until a uniform system had been agreed upon.* But the recent demonstration in stereophonic reproduction by the B.B.C. in special transmissions during broadcasting hours has whetted the appetite not only of the hi-fi enthusiasts but also the experimenter. This, I believe, is the first time the B.B.C. (who at last are getting a little more enterprising) have done anything like this during normal broadcasting periods. Many, many long years ago they broadcast a number of musical tones of even intensity so people could tell how good their reproduction was. Instead, everybody found out how bad it was, and they were so inundated with enquiries and complaints they seem to

* These notes were written just before the announcement that the Pye group were to issue the first British stereo discs on the 2nd June—EDITOR.

have steered clear of doing anything like it since.

Realism

No doubt many readers will have attended stereophonic demonstrations and have been most impressed, not so much at the quality of the reproduction and frequency range, but at its feeling of spaciousness and the sense of positioning it gives. Under ideal conditions the sounds seem to be coming from anywhere except the actual position of the loudspeakers! One of the earliest really effective ones I heard was nearly ten years ago at Philips (in Eindhoven) where I went as a guest during their jubilee celebrations. Since then, of course, there have been many new developments and, naturally, I have since been to even more impressive demonstrations over here. I hope to have the opportunity of visiting Philips again to see the further progress they have made in this respect. There were just three of us (and two engineers) in the demonstration theatre at the time and the loudspeakers were concealed. It was quite impossible to tell where the sound was coming from. As you moved towards the spot where you suspected one might be, the source of sound seemed to move away from you to a quite different point. It was rather like trying to chase an echo. This was, of course, a permanently arranged demonstration theatre—not one planned for just the duration of an exhibition as were the more recent ones I have heard. These have been quite good enough to feel, if you close your eyes, that you are standing among the various instrumentalists of the orchestra. To go back to one loudspeaker with all the sound coming from a single source (however good it is) leaves the keen experimenter vaguely dissatisfied. It seems rather like listening with one ear only.

Effective results are obtained by using loudspeaker systems employing a network of filters, etc., but the chief virtue of such an arrangement is the extension of the frequency

range. When, as in the B.B.C. stereophonic transmissions two separate channels are used (and two separate receivers at the listening end) remarkable results can be achieved with normal, inexpensive equipment. However, the B.B.C. made it clear that it was merely an experiment and was not to be taken as an indication that stereophonic broadcasting is likely in the foreseeable future. Nor could entirely satisfactory reception be obtained by listeners on one channel only, of course. Hence, as I mentioned a couple of months ago, it is to the gramophone with two channels in a single recording groove that those with a taste for stereophonic reproduction must look.

Through Other Ears

I was rather hoping to have heard from readers situated in more distant regions on their reception of these transmissions. They may well have got poorer reproduction than from the normal single channel transmissions. I did, however, manage to induce a number of friends to specially listen to the re-broadcast in their own homes under the conditions recommended by the B.B.C. and to give me their opinions.

These varied from those whose only

and their original title was the Columbia Graphophone Co. Ltd.

The second informative letter comes from R.G.W. (Coventry) on the question of the life of modern L.P. records. Using standard Collaro 3-speed changer units with Studio "O" pick-ups arranged for continuous "repeat," the records are found to give 2,500 playings before the signal/noise ratio has noticeably depreciated when heard over a high fidelity monitor.

The conditions were perhaps a little exceptional as the turntable cabinets were baize lined to prevent the ingress of dust, and the stop/start switch could be operated from outside the box. This figure was obtained using a sapphire stylus, which was found satisfactory for 1,700 hours playing (about 8 months all-day use). Now a diamond stylus has been fitted to each of the heads. At the time of writing they had only been in use for two months, but a longer life than with the sapphire type is expected. Many thanks to both for the information.

"Two-way" Radio

Thinking of "dual" reception to obtain special effects reminds me of the years just before the superhet receiver became usual.

Centre Tap

talks about items of general interest

reaction was to hear the sound "more spread out over the room" (only natural with two loudspeakers going) to those who claimed to hear the ping-pong ball being hit from one loudspeaker to the other. They also felt the train was rushing in on the first and out of the second loudspeaker. They all agreed that the noises were much more effective than the musical items. Personally, I thought the operatic selection was the most realistic and that there really was a space between the orchestra and the singers.

Incidentally, the programme was planned by the gramophone companies—hence the gramo. invasion into this column is particularly strong this month!

Still in the Groove

Continuing with the gramophone as the main theme, there are a couple of interesting letters from readers. The first, from R.E.B., of Stockton-on-Tees, on the origin of the word *gramophone*. It was the trade name of H.M.V. Columbia called theirs the Grafonda

Three-valve, sometimes four, straight receivers were the order of the day, the keen types using bandpass tuners and the still keener types experimenting hopefully with various forms of a.v.c. Multi-electrode valves were still to come. Hence the superhet was both cumbersome (with numerous triodes) and costly. The less knowledgeable constructors didn't like them, alleging poorer quality than the "straight." This was often true, due to overloading in the various stages; but it was even more true, although not admitted, that they were more than a little scared of the complication.

The straight receivers, although very sensitive, suffered badly from the effects of fading when tuned to the more distant stations, and as the straights did not have sufficient gain a.v.c. was hardly a worthwhile proposition. So to overcome fading the keen types used "diversity receivers." This simply meant that two tuning circuits were fitted to one receiver. Thus, to overcome the effects of fading one simply found

another station broadcasting the same programme and tuned the second circuit to that. It was economical and gave the keen types another knob to play with. The belief that the more knobs you had the better (called "having everything under control") was a long time dying. Incidentally, the business of "simultaneous" broadcasting by virtually all B.B.C. stations was even more general then than it is now. Hence the signals reinforced each other, each being on different wavelengths as they were then known. As fading rarely occurred on both frequencies at the same time, a reasonably constant level of volume could be obtained. The snag was that the signals wouldn't keep in phase—but it made a very pleasant change from dressing up the same old circuits in different clothes!

Dry Subject

When a couple of correspondents recently wrote of the difficulties of garden shed hobbyists, I put up the subject for airing. The response was unusually small with only one practical suggestion—Rustfoe paper. Arriving too late to include in last month's issue was a letter from L.G. (Deansgate Terrace, Grimsby), also drawing attention to Rustfoe V.P.I. (Vapour Phase Inhibitor) papers. He has found them effective for the storage of drills, screws, etc., which are fully protected even if left in cartons in a dampish cupboard after a period of two years. He also mentions a dodge which he has found useful to a lesser extent. A piece of camphor in a closed tin will help to protect iron articles from rust.

On this subject I had hoped to hear of some novel method of automatically ventilating damp workshops. For some years a neighbour, a heated greenhouse fan, has pestered me to "invent" him something which will automatically ventilate his hot-houses by opening and shutting the windows according to the outside temperature.

Thermostatic control of the inside temperature is easy and certain, and he was sure a clever bloke, like me, could devise a means of fluctuating the window opening if I put my mind to it. "There's a fortune in it," he used to urge me. He conceived the idea I was a clever bloke since I twice diagnosed the trouble with his t.v. with lucky first-time shots and once restored his thermostat to working order. He is a grape-growing enthusiast; and for those who know nothing

of the tribulations of grape-growers in a variable climate like ours, I should point out that they must not be subject to rapid changes in temperature and yet require plenty of air. This entails shutting them up at night and opening the ventilating windows notch by notch as the daytime temperature rises and closing them down (also notch by notch) as it falls. This rather knocks the fun out of it, so most people would rather nip round the corner and buy a bunch. Not so with the keen types. The greater the odds against them the more determined they become to grow their own grapes. But, after all, even the keenest among them cannot spend their whole lives hovering round the hot-house with a thermometer in one hand. Apparently none of our readers are also grape-growers, otherwise we might have had automatic window wagglers years ago.

By the way, I have never disillusioned him about his belief in my cleverness. On the contrary, I encourage it by luring him into my shack where under his very eyes he sees things working "automatically" (by relays) and neons that light up without connections. It's nice to have someone who really believes you are the cat's whiskers and that the invention of an automatic window waggler is a mere matter of routine if only you could be induced to bring your great mind to bear on the matter. Certainly, as far as I could trace, no one had ever marketed such a device, which, since I have come to think of it, would also be useful to those with damp workshops.

Now, oddly enough, since we touched on the point in this column, an automatic ventilator has appeared on the market. I have not been able to go into it yet; perhaps when I get back to normal routine . . . Incidentally, you may have guessed by my references to the B.B.C.'s stereo transmissions, that I am out of hospital and dashing off these notes during a short spell of home convalescence before going off for some sea air—and hoping there will be no need for closing windows where I am going!

However, I gather that this device is purely mechanical and is operated by a push rod which opens or shuts the window as required. If any reader has a bright idea for an improved electrical model there is apparently still an opportunity to cash in on that fortune which my grape-growing neighbour believes merely awaits picking up by a "bloke who's a bit clever with electricity."

SELF-CALIBRATING TRANSISTOR TESTER

We are advised that the Westinghouse M-3 rectifier specified for use in this tester is unsuitable for the purpose, and that the Westinghouse 14D/133 should be substituted.

The ** ** ** ** ** ** ** ** ** ** ** ** ****

DOUBLE SUPERHET

** ** ** ** ** ** ** ** ** ** ** ** **** by F. G. RAYER

THE USUAL TYPE OF SUPERHET WITH 465 kc/s intermediate frequency can be perfectly satisfactory for long and medium wave reception, but tends to suffer from second channel interference on the short wave bands. To overcome this, a tuned r.f. stage is frequently used to increase second channel rejection. Alternatively, a higher intermediate frequency may be employed. Indeed, one of these methods (r.f. stage, or high intermediate frequency) will be found in all communications and similar highly efficient receivers.

How second channel interference (or "image" interference, as it is also called)

purpose in eliminating it, though they will, of course, reduce interference from stations on an adjacent frequency.

With a simple superhet, only one tuned circuit (the aerial circuit) is able to combat such second channel interference. This is insufficient, so that stations around 27.4 metres (or 10.93 Mc/s) can cause serious trouble. The same difficulty exists as the receiver is tuned throughout the band, second channel interference always being found 930 kc/s (twice the i.f.) above the point to which the receiver is tuned. Even with a selective r.f. stage, some second channel interference remains, and can become more troublesome

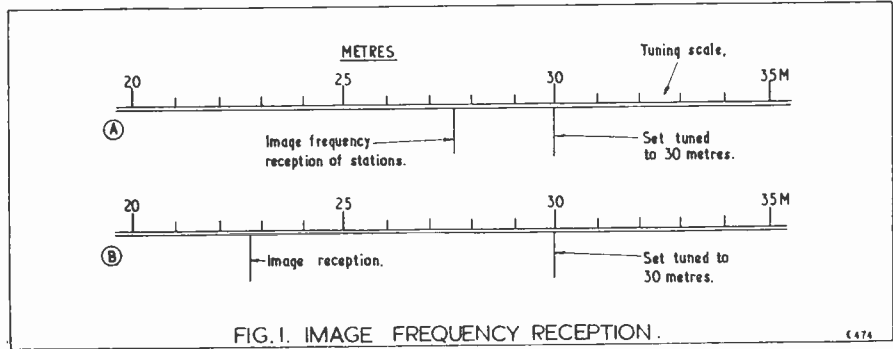

arises will become clear from Fig. 1. A portion of a s.w. band tuning scale is shown, and the receiver is assumed to be tuned to 30 metres, or 10 Mc/s. With a 465 kc/s i.f., the oscillator will be operating at 465 kc/s above the signal frequency. That is, at 10,465 kc/s. A station at 10,000 kc/s (10 Mc/s) will beat with the 10,465 kc/s oscillator, producing the 465 kc/s i.f. signal which is amplified by the i.f. stage, and heard in the speaker. However, stations around 10,930 kc/s, or 465 kc/s higher in frequency than the oscillator, will also produce a 465 kc/s i.f. signal. This constitutes second channel or image interference. Highly selective i.f. stages cannot reduce it, or serve any useful

as wavelengths below 20 metres are tuned. Because of this, many high-class communications receivers do not rely upon the r.f. stage to remove image interference.

Higher I.F.

By using a high intermediate frequency, the point at which second channel interference arises can be shifted well away from the wavelength to which the receiver is tuned. This is shown at "B" in Fig. 1, which is for an i.f. of 1.6 Mc/s. With the receiver still tuned to 30 metres, the image reception point has become approximately 22.7 metres. Even a single tuned circuit can give almost complete rejection of signals so far removed

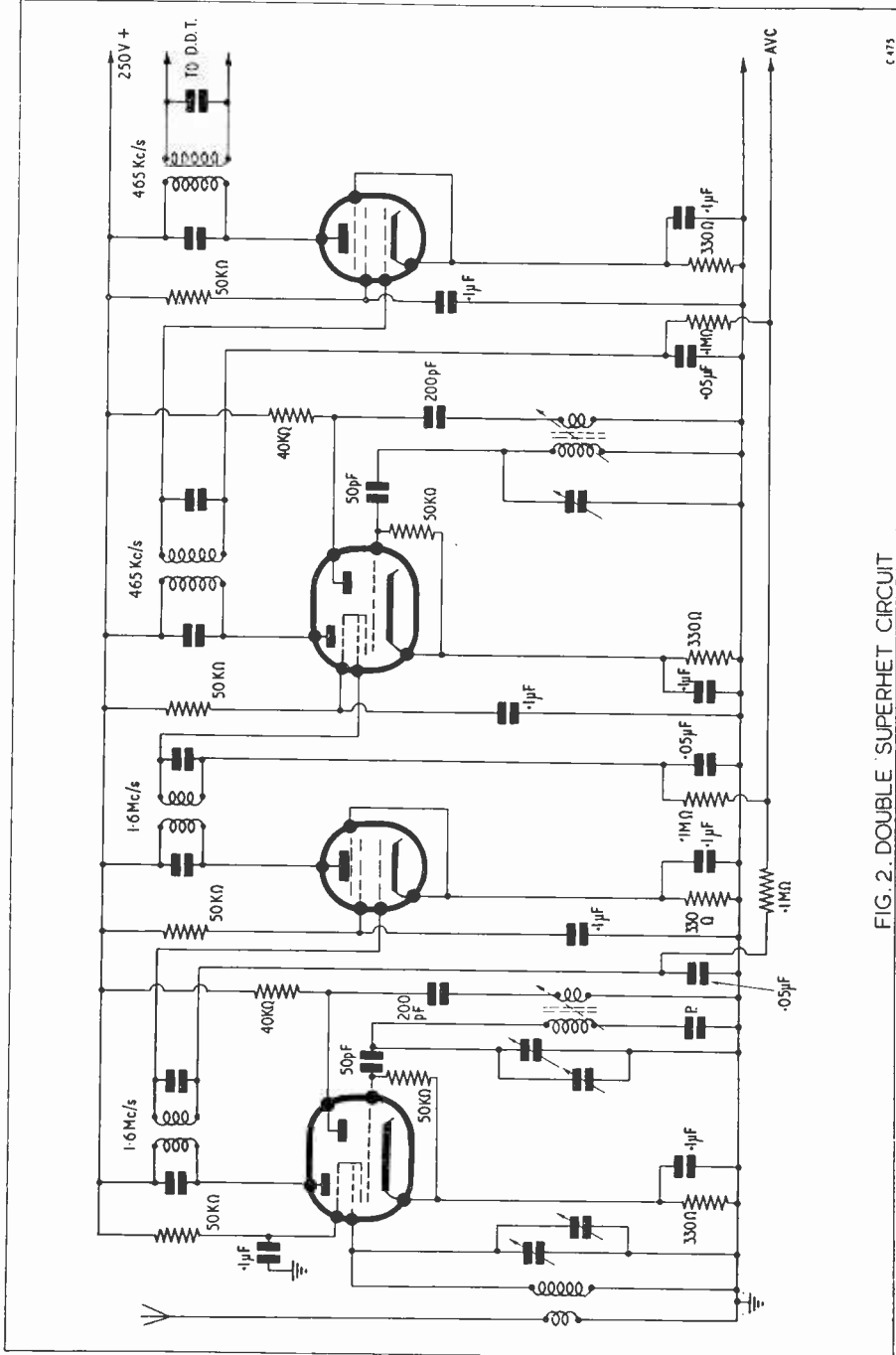

FIG. 2. DOUBLE SUPERHET CIRCUIT

C.175

from the tuning point. With an r.f. stage, rejection would be so good that all second channel interference would have ceased.

Such high intermediate frequencies are not required for l.w. or m.w. receivers, where 465 kc/s will normally be adequate. If a high i.f. is employed, adjacent-channel selectivity will fall, so that interference may arise from stations of *near* wavelength. With high efficiency s.w. equipment, the double superhet circuit is consequently often used. This has the advantages of high second channel rejection, and excellent adjacent-channel selectivity. Furthermore, as several stages are not required to operate on the same frequency, stability is easily maintained. This type of circuit is thus well worth trying, and can give excellent results.

Two F.C. Stages

A typical double-superhet circuit appears in Fig. 2, the usual double-diode-triode and output stages conforming to normal pattern. A 1st i.f. of 1.6 Mc/s is not essential, but is suggested because oscillator coils for this frequency may be obtained. An oscillator coil intended for 465 kc/s cannot be employed. "P" is the usual padder, of the value recommended by the coil maker. Other bands can be selected by switching in the usual way.

The 1st frequency changer stage operates exactly as with a simple superhet, except that the oscillator tunes 1.6 Mc/s (1,600 kc/s) above the aerial frequency. The 1st f.c. stage output is amplified by one i.f. stage at 1.6 Mc/s. The 1.6 Mc/s signal is then fed to the signal grid of the 2nd f.c. stage. It is convenient to use a 2nd i.f. of 465 kc/s, which means that the 2nd f.c. oscillator must be tuned to 2,065 kc/s (465 kc/s higher than 1,600 kc/s). The resultant 465 kc/s signal is amplified by a 465 kc/s i.f. stage, after which it reaches a conventional double-diode-triode stage.

No variable tuning is required in the 2nd f.c. stage, so that a 2-gang tuning condenser is sufficient. Extra i.f. stages, at either 1.6 Mc/s or 465 kc/s, may be added in the usual way. An r.f. stage can also be provided if desired, a 3-gang condenser then being employed.

Practical Construction

Its inherent stability makes such a circuit relatively easy to build. Home-constructed s.w. superhets with some free chassis space may be modified by adding the extra valves, and converting the 1st f.c. stage for 1.6 Mc/s working. To secure a good layout, it may be best to use these transformers in the positions previously occupied by the 465 kc/s components. The two 465 kc/s transformers, with 2nd f.c. and i.f. stages, can then be placed near the double-diode-triode stage.

The 2nd f.c. oscillator coil will have to be tuned to 2,065 kc/s, or a little under 150 metres. A 465 kc/s m.w. oscillator coil is therefore suitable. As frequency drift will be serious, a small air-spaced trimmer is recommended for use with the coil. The padder will usually be unnecessary.

Values shown in Fig. 2 are for 6K8's in the f.c. stages, with 6K7's in the i.f. stages, but other valves are satisfactory, the cathode, screen grid and oscillator anode resistors being adjusted in value to suit, if necessary. It is possible to use common cathode and screen grid resistors without causing instability.

With such a circuit, correct alignment is very important. Wrong alignment alone can result in no signals whatever being heard. If any difficulty arises, the secondary of the 2nd 1.6 Mc/s transformer may be taken to the detector stage. This will allow the 1st f.c. stage to be dealt with by trimming at a low wavelength, and adjusting coil cores at a high wavelength, on each band. The 1st pair of i.f.t.'s can also be aligned. The full circuit is then restored, and the 2nd f.c. oscillator coil core and trimmer adjusted for maximum sensitivity. Complete and careful adjustment of all tuned circuits throughout can then follow.

If local ship or shore transmitters around 465 kc/s (645 metres) are troublesome, the 2nd i.f. can be shifted a little, and the set re-aligned. In some areas this is well worth while.

110 kc/s 2nd I.F.

The double superhet circuit may be used with 465 kc/s transformers in the first stages, and 110 kc/s components in the later stages. This will not increase second channel rejection, for the reasons shown in Fig. 1, but will give very high adjacent-channel rejection, without the instability which so easily arises with several stages all working on one intermediate frequency.

For such a receiver, 1st f.c. and i.f. stages remain unchanged, with the normal 465 kc/s oscillator coil and padder. The 2nd f.c. oscillator circuit will be tuned to 575 kc/s, or about 522 metres. A 465 kc/s type oscillator coil intended for the l.w. band will thus be satisfactory. Suitable transformers will sometimes be found in rather old receivers where intermediate frequencies of around 90 to 120 kc/s were employed, or may be obtained from Denco (Clacton) Ltd.

When making up a new receiver with such a circuit, 1.6 Mc/s and 465 kc/s transformers can generally be chosen with advantage, for the reasons explained, though there is of course no reason why these exact frequencies should be employed.

TRANSISTORISED MICROPHONE PRE-AMPLIFIERS

By C. M. Pearson, B.Sc.

A TRANSISTOR MICROPHONE PRE-AMPLIFIER built into the microphone case can be of great benefit, particularly in the reduction of hum pick-up. The transistor pre-amplifier may give considerable voltage gain and a low output impedance, thus permitting the use of long microphone leads without loss of volume or loss of high frequency response.

An amplifier designed for operation from a moving coil microphone may have a voltage gain of the same order as the step-up ratio of the normally used microphone transformer, but have only a fraction of the output impedance of the transformer. Furthermore, the microphone circuit no longer contains any transformer to pick up hum from mains wiring.

If the microphone amplifier is required to work into very long lengths of coaxial cable, an additional transistor stage will permit the correct termination of the cable at its far end so that there will be no high frequency losses.

It may not be generally realised how short a length of coaxial cable is needed to restrict the high frequency response of a crystal microphone or a moving coil microphone with built-in step-up transformer. Four feet of 75Ω coax. will cut the former off at

approximately 2 kc/s and the latter at approximately 10 kc/s. With a single transistor amplifier (Figs. 1 to 4) the high frequency cut off will be raised to approximately 200 kc/s, and 100 feet of coax. would be necessary to restrict the response to 10 kc/s. If an emitter follower stage (Figs. 5 and 6) is added and the cable is correctly terminated at its far end with a 75Ω resistor, the gain will be reduced, but any length of cable may be used with no loss of top notes.

Referring to the circuit diagrams, Fig. 1 is the simplest possible circuit for a moving coil microphone and will give a gain of approximately 80 (38 dB). Fig. 2 is suitable for crystal microphones and will give a gain of approximately 4 (12 dB). Figs. 3 and 4 are improved circuits giving temperature compensation and have the same gains as Figs. 1 and 2. Fig. 5 is a grounded collector stage for 75Ω output and may be applied to the circuits shown in Fig. 1 or Fig. 2. Fig. 6 is a grounded collector stage for the circuits in Figs. 3 and 4. The input of the grounded collector stage should be connected to the lower end of R_L .

The more complicated circuits of Figs. 3, 4 and 6 should be used for preference, and can be operated from a 15V deaf-aid battery.

The Teletron "Companion" *continued from page 883*

Operating the Receiver

As was mentioned above, tuning of the receiver is carried out by adjusting the position of the core of L_1 inside the coil former. The simplest method of tuning consists of setting the volume control to not more than half-way along its track and adjusting the core of L_1 . A whistle will then be heard as the required station is tuned in. The volume control should next be carefully adjusted until the whistle disappears, whereupon some slight final adjustment of both controls will enable the signal to be received at the desired volume.

It is possible that a number of readers may wish to fit a tuning scale to the receiver. A suitable scale is illustrated in Fig. 5, wherein the method of fixing is also illustrated. The scale is glued around the core of L_1 , as

shown, whereupon it may be observed through the cabinet aperture.

In areas of poor signal strength, sensitivity may be improved by connecting a short aerial to the receiver. This aerial may be connected to either tag 1 or tag 6 of L_1 . Although the risk is low, there is a slight possibility that audio howl may occur when the set is operated. This trouble may be cleared by reversing the secondary connections (green and red), of transformer T_2 .

There is, finally, the point that some constructors may wish to connect headphones to the receiver. When high impedance headphones are employed these may be inserted in series with the collector of TR_3 . Low impedance deaf-aid phones should be connected across the secondary of transformer T_2 .

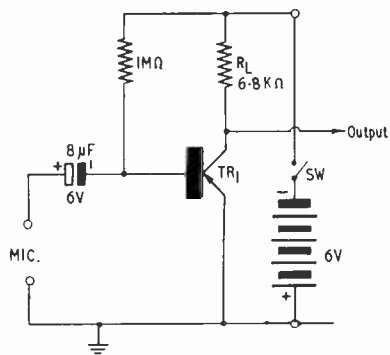

FIG. 1.
Amplifier for moving coil microphone.

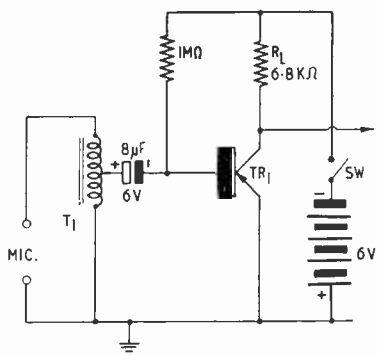

FIG. 2.
Amplifier for crystal microphone.

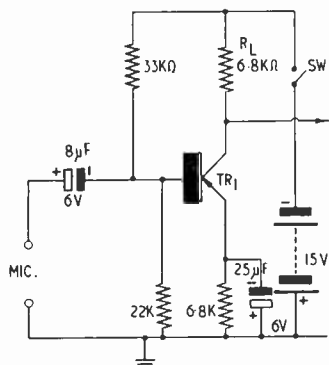

FIG. 3.
Amplifier for moving coil microphone.

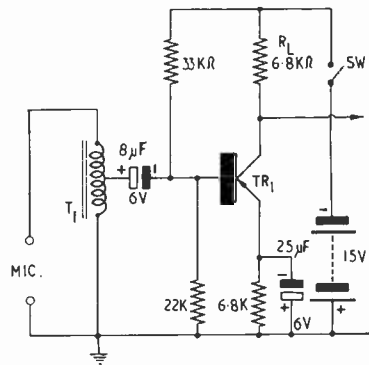

FIG. 4.
Amplifier for crystal microphone.

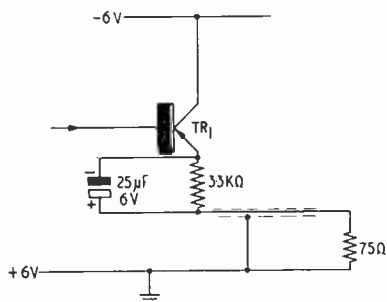

FIG. 5.
Grounded collector stage for FIGS. 1 & 2.
TR₁ = OC71 or equivalent

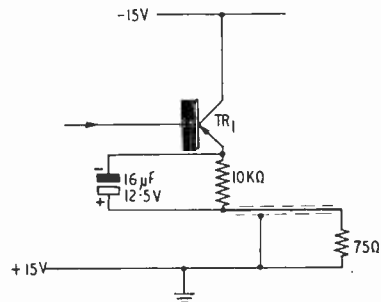

FIG. 6.
Grounded collector stage for FIGS. 3 & 4.
T₁ = Ardenite T1075 transformer.

THE RADIO SHOW—EARLS COURT, 1958

26th AUGUST—6th SEPTEMBER

PRELIMINARY LIST OF EXHIBITORS

Name	Address	Stand No.
Admiralty	C.N.I. Dept., Whitehall, S.W.1	*
Aerialite Ltd.	Castle Works, Stalybridge, Cheshire	* 5
Air Ministry	Information 1, Parliament Square House, S.W.1	*
Ambassador Radio & TV Ltd.	Camp Bird House, 39 Dover Street, W.1	26
Antiference Ltd.	Bicester Road, Aylesbury, Bucks.	22
Argosy Radiovision Ltd.	Eastern Avenue West, Romford, Essex	39
AVO Limited	Avocet House, 92-96 Vauxhall Bridge Road, S.W.1	60
B.M.B. (Sales) Ltd.	High Street, Crawley, Sussex	122
Balcombe, A. J., Ltd.	52-70 Tabernacle Street, E.C.2	37
Barclays Bank Ltd.	54 Lombard Street, E.C.3	101
Belling & Lee Ltd.	Gt. Cambridge Road, Enfield, Middlesex	49
Bernards (Publishers) Ltd.	The Grampians, Western Gate, W.6	126
Bowmaker Ltd.	Bowmaker House, Lansdowne, Bournemouth, Hants	211
British Broadcasting Corp.	Broadcasting House, W.1	*
British Radio & TV (Publishers) Ltd.	46 Chancery Lane, W.C.2	124
British Railways	British Transport Commission, Pub. Div., 222 Marylebone Road, N.W.1	112
Broomhall Joinery Co. Ltd.	222 High Street, Uxbridge, Middlesex	103
Bulgin, A. F., & Co. Ltd.	Bye-Pass Road, Barking, Essex	56
Burwell Products Ltd.	116 Blackheath Road, S.E.10	219
Bush Radio Ltd.	Power Road, Chiswick, W.4	3 & 27
Champion Elec. Corp.	8A Eccleston Street, S.W.1	206
Channel Electronic Inds. Ltd.	Dunstan Road, Burnham-on-Sea, Somerset	213
Cole, E. K., Ltd.	Ekko Works, Southend-on-Sea, Essex	29
Collaro Ltd.	Ripple Works, Bye-Pass Road, Barking, Essex	35
Co-operative Wholesale Society Ltd.	1 Balloon Street, Manchester, 4	1
Cossor Radio & TV Ltd.	Cossor House, Highbury Grove, N.5	10
Dallas, John E., & Sons Ltd.	Dallas Building, Clifton Street, E.C.2	223
Decca Record Co. Ltd.	1-3 Brixton Road, S.W.9	215
Design Furniture Ltd.	Carnwath Road, Fulham, S.W.6	119
Dubilier Condenser Co. (1925) Ltd.	Ducon Works, Victoria Road, North Acton, W.3	55
Dynatron Radio Ltd.	St. Peter's Road, Furze Platt, Maidenhead, Berks	46
E.M.I. Institutes Ltd.	E.M.I. Advertising Div., Hayes, Middlesex	*
E.M.I. Sales & Service Ltd.	Hayes, Middlesex	48
Econasig Co. Ltd.	92 Victoria Street, S.W.1	225
Electric Audio Reproducers Ltd.	The Square, Isleworth, Middlesex	62
"Electrical & Radio Trading"	Sales Promotion & Service Dept., 96 Long Acre, W.C.2	123
Ever Ready Co. (Gt. Brit.) Ltd.	Hercules Place, Holloway, N.7	16
Ferguson Radio Corp. Ltd.	105 Judd Street, W.C.1	17
Ferranti Radio & TV Ltd.	41/47 Old Street, E.C.1	21
Fidelity Radio Ltd.	11 Blechynden Street, W.11	54
Fortiphone Ltd.	247 Regent Street, W.1	106
Garrard Eng. & Mfg. Co. Ltd.	Newcastle Street, Swindon, Wilts	51
General Electric Co. Ltd.	Magnet House, Kingsway, W.C.2	8
General Post Office	Headquarters Bldg., St. Martin's-le-Grand, E.C.1	*
Goodmans Industries Ltd.	Axiom Works, Wembley, Middlesex	34
Gramophone Co. Ltd.	105 Judd Street, W.C.1	45 & 118
Greater London Fund for the Blind	2 Wyndham Place, W.1	*
Hart, Alfred, & Co. Ltd.	243 Upper Street, N.1	227
Hill, Thomas H., & Sons Ltd.	Astra Works, Worcester Road, Kidderminster, Worcs	217
Hobday Bros. Ltd.	21-27 Great Eastern Street, E.C.2	121
Hunt, A. H. (Capacitors), Ltd.	Bendon Valley, Garratt Lane, S.W.18	47
Independent Television Authority	14 Princes Gate, S.W.7	*
Invicta Radio Ltd.	100 Great Portland Street, W.1	2
J-Beam Aerials Ltd.	Westonia, Weston Favell, Northampton	14
Keith Prowse & Co. Ltd.	90 New Bond Street, W.1	68
Kerry's (Gt. Brit.) Ltd.	Warton Road, Stratford, E.15	23
Kolster-Brandes Ltd.	Footscray, Sidcup, Kent	43
Labgear Ltd.	Willow Place, Cambridge	31
Linguaphone Institute Ltd.	207-209 Regent Street, W.1	205
Lloyds Bank Ltd.	Premises Dept., 71 Lombard Street, E.C.3	7
McMichael Radio Ltd.	Langley Park, Slough, Bucks	42
Marconiophone Co. Ltd.	105 Judd Street, W.C.1	33
Margolin, J. & A., Ltd.	"Plus-a-Gram House," 112/116 Old Street, E.C.1	107
Masteradio Ltd.	10/20 Fitzroy Place, N.W.1	4
Meadow Dale Mfg. Co. Ltd.	The Dale, Willenhall, Staffs	105
Mercantile Credit Co. Ltd.	Argyll House, 246/250 Regent Street, W.1	210
Midland Bank Ltd.	Head Office, Poultry, E.C.2	201
Mullard Ltd.	Mullard House, Torrington Place, W.C.1	41
Multicore Solders Ltd.	Maylands Avenue, Hemel Hempstead, Herts	63
Murphy Radio Ltd.	Welwyn Garden City, Herts	11

<i>Name</i>	<i>Address</i>	<i>Stand No.</i>
National Institute for the Deaf	105 Gower Street, W.C.1	102
National Provincial Bank Ltd.	15 Bishopsgate, E.C.2	6
Pam (Radio & TV) Ltd.	295 Regent Street, W.1	65
Perdio Ltd.	Dunstan House, St. Cross Street, E.C.1	204
Perth Radios Ltd.	Marten House, 39/47 East Road, N.1	12
Peto Scott Elec. Insts. Ltd.	Weybridge, Surrey	19
Philco (Overseas) Ltd.	30/32 Grays Inn Road, W.C.1	52 & 53
Philips Electrical Ltd.	Century House, Shaftesbury Avenue, W.C.2	28
Pilot Radio Ltd.	Park Royal Road, N.W.10	58
Portogram Radio Elec. Inds. Ltd.	"Preil Works," St. Rule Street, S.W.8	108
"Practical Wireless" & "Practical Television"	Tower House, Southampton Street, W.C.2	44
Pye Limited	Cambridge	50
Radio & Allied Inds. Ltd.	Langley Park, Slough, Bucks	24
Radio Gram. Dev. Co. Ltd.	Eastern Avenue West, Romford, Essex	*
Radio Society of Gt. Brit.	New Ruskin House, Little Russell Street, W.C.1	104
Record Housing	Brook Road, Wood Green, N.22	9
Regentone Radio & TV Ltd.	Eastern Avenue West, Romford, Essex	57
Roberts' Radio Co. Ltd.	Creek Road, East Molesey, Surrey	30
Rola Celestion Ltd.	Ferry Works, Thames Ditton, Surrey	40
Siemens Edison Swan Ltd.	155 Charing Cross Road, W.C.2	215
Slingsby, H. C., Ltd.	89, 95/97 Kingsway, W.C.2	218
Spencer-West Ltd.	North Quay, Gt. Yarmouth, Norfolk	18
Standard Telephones & Cables Ltd.	Connaught House, Aldwych, W.C.2	13
Stella Radio & TV Co. Ltd.	Oxford House, 9/15 Oxford Street, W.1	212
Taylor Elec. Instrs. Ltd.	Montrose Avenue, Slough, Bucks	59
Telegraph Condenser Co. Ltd.	Wales Farm Road, W.3	36
Telerection Ltd.	Antenna Works, St. Pauls, Cheltenham, Glos	207 & 214
Telesurace Ltd.	14 Windmill Street, W.1	15
Thompson, Diamond & Butcher Ltd.	5/9 University Street, W.C.1	20
Ultra Electric Ltd.	Western Avenue, Acton, W.3	61
Valradio Ltd.	Browells Lane, Feltham, Middlesex	32
Vidor Ltd.	Erith, Kent	115
Walter Instruments Ltd.	Garth Road, Morden, Surrey	228
Waveforms Ltd.	Radar Works, Truro Road, N.22	114
Westinghouse, Brake & Signal Co. Ltd.	82 York Way, King's Cross, N.1	113
Westminster Bank Ltd.	Premises Dept., Post Office Court, 10 Lombard Street, E.C.3	64
Whiteley Elec. Radio Co. Ltd.	Radio Works, Victoria Road, Mansfield, Notts	203
Wireless & Electrical Trader	Dorset House, Stamford Street, S.E.1	216
Wireless World Electronic and Radio Engineer	Dorset House, Stamford Street, S.E.1	38
Wolsley Electronics Ltd.	Cray Avenue, St. Mary Cray, Orpington, Kent	125
Winston Electronics Ltd.	Govett Avenue, Shepperton, Middlesex	

* First Floor Exhibitors—numbers not yet allocated.

DEMONSTRATION ROOMS/OFFICES

Ambassador Radio & TV Ltd.	Z.3
Bush Radio Ltd.	Z.24
Cole, E. K., Ltd.	Z.7 & Z.8
Cossor Radio & TV Ltd.	Z.34
Dallas, John E., & Sons Ltd.	Z.26 & Z.27
Decca Record Co. Ltd.	Z.2
E.M.I. Sales & Service Ltd.	Z.11
Ferguson Radio Corp. Ltd.	Z.36
Ferranti Radio & TV Ltd.	Z.21
General Electric Co. Ltd.	Z.35
Gramophone Co. Ltd.	Z.9
Hobday Bros. Ltd.	Z.10
Invicta Radio Ltd.	Z.19
Multicores Solders Ltd.	Z.14 & Z.17
Mullard Ltd.	Z.28, Z.29 & Z.30
Murphy Radio Ltd.	Z.1
Pam (Radio & TV) Ltd.	Z.33
Philips Electrical Ltd.	Z.16
Pye Ltd.	Z.6
Radio & Allied Industries Ltd.	Z.15
Radio Gramophone Dev. Co. Ltd.	Z.32
Siemens Edison Swan Ltd.	Z.31
Standard Telephones & Cables Ltd.	Z.4
Telegraph Condenser Co. Ltd.	Z.22
Vidor Ltd.	Z.25
Walter Instruments Ltd.	Z.12
Whiteley Elec. Radio Co. Ltd.	Z.18

LIST OF EXHIBITORS IN THE "AUDIO HALL"

Name	Address	Stand No.
Allan, Richard, Radio Ltd.	Taylor Street, Batley, Yorks.	430
Altobass Ltd.	Percy Road, Leicester	439
Antony, Francis, Ltd.	Pennare House, Veryan, Nr. Truro, Cornwall	406
BTH Sound Equipment Ltd.	Reynold's House, 5 Gt. Newport Street, W.C.2	437
Balcombe, A. J., Ltd.	52/70 Tabernacle Street, E.C.2	427
Beam-Echo Ltd.	Witham, Essex	448
Brenell Engineering Co. Ltd.	1A Doughty Street, W.C.1	440
C.Q. Audio Ltd.	2 Sarnesfield Road, Enfield, Middlesex	411
Clarke & Smith Mfg. Co. Ltd.	Melbourne Works, Wallington, Surrey	403
Classical Record News Ltd.	99 Mortimer Street, W.1	407
Cole, E. K., Ltd.	Ekco Works, Southend-on-Sea, Essex	442
Collaro Ltd.	Ripple Works, Bye-Pass Road, Barking, Essex	414
Cosmocord Ltd.	Eleanor Cross Road, Waltham Cross, Herts	444
Cossor Radio & TV Ltd.	Cossor House, Highbury Grove, N.5	404
Decca Record Co. Ltd.	1/3 Brixton Road, S.W.9	425
Dynatron Ltd.	St. Peter's Road, Furze Platt, Maidenhead, Berks	413
E.A.P. (Tape Recorders) Ltd.	Bridge Close, Oldchurch Road, Romford, Essex	416
E.M.I. Insitutes Ltd.	E.M.I. Advertising Div., Hayes, Middlesex	401
E.M.I. Sales & Service Ltd.	Hayes, Middlesex	415
Electric Audio Reproducers Ltd.	The Square, Iselworth, Middlesex	431
Electronic Reproducers Ltd.	39 Dover Street, W.1	417
Expert Gramophones Ltd.	39/41 New Oxford Street, W.C.1	424
Ferguson Radio Corp. Ltd.	105 Judd Street, W.C.1	432
Ferranti Radio & TV Ltd.	41/47 Old Street, E.C.1	446
Garrard Eng. & Mfg. Co. Ltd.	Newcastle Street, Swindon, Wilts	438
General Electric Co. Ltd.	Magnet House, Kingsway, W.C.2	443
Goodmans Inds. Ltd.	Axiom Works, Wembley, Middlesex	434
Grampian Reprods. Ltd.	Hanworth Trading Estate, Feltham, Middlesex	435
Jason Motor & Electronic Co.	3/4 Gt. Chapel Street, W.1	441
Kolster-Brandes Ltd.	Footscray, Sidcup, Kent	402
Lustraphone Ltd.	St. George's Works, Regents Park Road, N.W.1	445
Magnafon Ltd.	3 Baggally Street, Bow, E.3	419
Multimusie Ltd.	Multicore Works, Maylands Avenue, Hemel Hempstead, Herts	418
Philco (Overseas) Ltd.	30/32 Grays Inn Road, W.C.1	449
Philips Electrical Ltd.	Century House, Shaftesbury Avenue, W.C.2	423
Pilot Radio Ltd.	Park Royal Road, N.W.10	428
Portogram Radio Electrical Inds. Ltd.	"Preil Works," St. Rule Street, S.W.8	412
Print & Press Services Ltd.	426 Camden Road, N.7	405
RCA Great Britain Ltd.	Lincoln Way, Sunbury-on-Thames, Middlesex	447
Rola Celestion Ltd.	Ferry Works, Thames Ditton, Surrey	410
Scientific & Technical Developments Ltd.	Melbourne Works, Wallington, Surrey	433
Soundrite Ltd.	82/83 New Bond Street, W.1	409
Sonomag Ltd.	2 St. Michael's Road, S.W.9	426
Tape Recorders (Electronics) Ltd.	784/788 High Road, Tottenham, N.17	420
Truvox Ltd.	15 Lyon Road, Harrow, Middlesex	421
W. & N. Electronics Ltd.	80/2 Uxbridge Road, Ealing, W.13	436
Walter Instruments Ltd.	Garth Road, Morden, Surrey	429
Whiteley Elec. Radio Co. Ltd.	Radio Works, Victoria Street, Mansfield, Notts	422

OFFICES

BTH Sound Equip. Ltd.	Z.458
Beam-Echo Ltd.	Z.452
E.A.P. (Tape Recorders) Ltd.	Z.455
Expert Gramophones Ltd.	Z.454
Grampian Reprods. Ltd.	Z.453
Jason Motor & Elec. Co.	Z.457
RCA Gt. Brit. Ltd.	Z.451
Tape Recorders (Electronics) Ltd.	Z.456
Whiteley Elec. Radio Co. Ltd.	Z.459

★ **VALVES** NEW TESTED AND GUARANTEED ★

1R5	8/-	6SL7GT	8/-	DH77	8/-	EF85	10/6
1S5	7/6	6SN7GT	8/6	DK91	8/-	EF91	7/-
1T4	7/6	6V6G	7/6	DK92	9/-	EF92	5/6
3S4	7/6	6V6GT	7/6	DK96	9/-	EK32	8/6
3V4	8/-	6X4	7/6	DL92	7/6	EL41	10/-
5U4G	8/6	6X3GT	7/6	DL94	8/-	EL84	10/6
5Z4G	9 5	12AT7	9/-	DL96	9/-	EL91	7/6
6AM6	7/-	12AU7	9/-	EA50	1/6	EY51	11/6
6AL5	6/6	12AX7	9/-	EB91	6/6	EZ35	8/-
6AT6	8/-	12K8GT	13/6	EBC41	8/-	EZ40	8/-
6B8G	7/6	12K7GT	8/6	EBF80	10/-	KT33C	9/6
6BA6	8/6	12Q7GT	8/6	ECC81	10/6	PCF82	11/-
6BE6	7/6	35Z4GT	8/6	ECC84	11/6	PL82	10/6
6BR7	10/6	35L6GT	9/6	ECF82	11/-	PY81	9/-
6BW6	8/6	53KU	11/6	ECH81	10/6	PCC84	10/6
6I5G	5/6	807	6/9	ECH42	10/-	U76	8/6
6I5GT	6/6	5763	10/6	ECL80	13/6	UBC41	10/-
6I7GT	8/6	DAF91	7/6	EF36	7/6	UCH42	10/-
6K7G	5/6	DAF96	9/-	EF37A	14/6	UF41	10/-
6K8B	9/6	DF91	7/6	EF32	5/6	UL41	10/-
6L6G	9/6	DF96	9/-	EF41	10/-	UY41	8/6
6Q7GT	8/6	DH76	8/6	EF80	9/6	VW76	8/6

Matched Pairs. EL84, 23/-; 6V6G & GT, 17/-; 6BW6, 18/-; KT33C, 19/6; 807 14/6 pair

1R5, 1T4, 1S5, 3S4, 3V4, DK91, DK92, DF91, DAF91, DL92, DL94, any four, 27/6 per set
P.P. Op. Transformers. Mr 3-15 ohms for EL84, 6V6, 6BW6, etc., 18/6; Op. Pen. 50mA, 5/6; 30mA, 4/6
Volume Controls. All valves, long spindle L/S 3/-, s.p. 4/-, d.p. 4/9, ext. spkr. control 3/-
W.W. Pots. Pre-set 3/-; 3W long spindle 5/6, s.p. 6/6
P.M. Speakers. 3 ohm. 5" 16/6, 6 1/2" 17/6, 8" 21/-, 10" 25/-, 12" 30/-
Coaxial Cable. 75 ohm 1/2" stranded, 8d. yd; semi-air spaced, 9d. yd; screen cable single and twin, 9d. yd
Coaxial Plugs 1/- each; **Sockets** 1/- each

P. and p. 9d. to £1: 1/6 to £2; over £2 post free. C.O.D. 2/6

R. COOPER G8BX 32 SOUTH END CROYDON SURREY CROYDON 9186

C.R.T. Isolation Transformers with 25% boost. Low capacity, a.c. mains 200/240V. For 2V, 4V, 63V and 13V tubes. All 12/6 each; 1-1 for H.C. shorts 10/6

Valveholders. 4, 5, 7 pin English and U.S.A. B7G, B9A, 1.0 Mc. B8G, 9d. each; B7G, B9A with screening can, 1/6; B12A, 1/3. Aladdin formers 1/2" with core, 8d. each

Scotch Boy Recording Tape, 1,200ft reels, 27/-
Jack Plugs, miniature standard, 3/-; **Sockets** 3/-
2-Gang Condensers, .0005 small size, 7/6 pair
I.F. Transformers, 465 kc/s, size, 7/6 pair

Capacitors, small mica, 5% 1pF to 100pF, 8d.; 120pF to 1,000pF, 9d.; 1,000V wkg. .01, .0015, .0025, .004, .005, 1/- each

Crystal Diodes, G.E.C., 1/6 each
Headphones, lightweight, 4,000 ohm, 16/6 pair
Ceramic Capacitors, close tol. 500V for V.H.F., 9d.
Paper Capacitors, tubular, .01, 1,000V, 1/-; 0.1 to 1.5 500V, 10d.

Paper Blocks, 4 1/2F, 1,000V wkg., 3/6
Rectifiers, contact cooled, 250V 50mA, 7/6; 85mA, 9/6
Reaction Condensers, .0001, .0003, .0005, 4/6 each
Heater Trans. 200/240V, 6.3V, 1.5A, 7/6
Resistors, 1/2 and 1/4 W, insulated, 4d. and 6d.: 1W, 8d. 6W W.W., 1/-; 10W, 2/-

Electrolytics. Wire ends. 25/25V, 1/6; 50/50V, 2/-; 12/50V, 9d.; 8/450V, 2/-; 16/450V, 2/9; 16/500V, 3/6; 32/450V, 4/-; 8+8/450V, 4/6; 8+16/450V, 4/6; can types: 16/450V, 3/6; 16+16/500V, 6/-; 32/500V, 6/6; 32/450V, 6/6; 20+20/450V, 4/6; 64+120/275V, 7/6

Wavechange Switches, midget: 1p 12W, 2p 6W, 3p 4W, 4p 3W, 4p 2W, long spindles, 4/6

Toggle Switches. QMB, s.p.s.t., 2/-; s.p.d.t., 3/3; d.p.s.t., 3/6; d.p.d.t., 4/-

Chokes, 80mA, 15H, 8/6; 100mA 10H, 10/6; 150mA 10H, 14/6

Solder, Multicore, 4d. yd; Sleeveing 2mm, 3d. yd

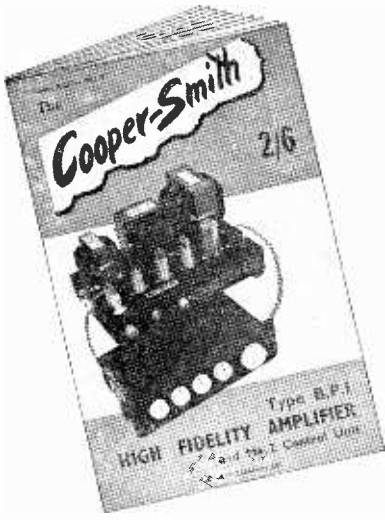

JUST PUBLISHED
The Cooper-Smith, type B.P.I.
HIGH FIDELITY AMPLIFIER
and Mk. 2 CONTROL UNIT
by Jack Cooper

A new addition to our Radio Reprint series (RR6), this book of 24 pp., plus laminated plastic board cover, is a worth-while addition to the Hi-Fi enthusiast's bookcase.

In addition to the material reprinted from our December 1957, January and February 1958 issues, two new chapters have been included, these giving much useful information on Signal Sources for use with the amplifier and on Choosing a Loudspeaker.

Complete circuit and constructional details of the balanced phase inversion amplifier are given, including point-to-point diagrams.

PRICE 2/6 Postage 2d.

Published by

DATA PUBLICATIONS LTD 57 Maida Vale · London W9

EDDY'S (NOTTINGHAM) LTD

(DEPT. RC) • 172 ALFRETON ROAD • NOTTINGHAM
Telephone Nottingham 74015

MIDGET BATTERY ELIMINATORS. To convert all types battery portables to mains operation. Actually smaller than h.t. battery alone. 57/6 each, plus 2/6 postage and packing. (Please state make and model number.)

MAP CASES 2/6 each, post 6d. extra. Ideal for service sheet holders and job cards, etc.

ACOS CRYSTAL MIKE INSERTS 4/11 each. High quality, can be used for tape recorders, baby alarms, musical instruments, etc. Post and packing 8d. extra.

ACOS CRYSTAL TURNOVER PICK-UPS (2 sapphire styli), 29/11 each, post 2/6, etc.

ALL NEW AND GUARANTEED

1D5	10/6	6BA6	6/6	7B7	8/6	12SN7GT	CY31	12/11	ECH35	10/11	EL42	10/-	PL82	9/6	
1HSGT	10/6	6B16	7/6	7C5	8/-	17/6	DAF96	9/6	ECH42	9/11	EL84	9/-	PL83	9/3	
1R5	7/11	6F1	13/11	7C6	8/-	12SQ7GT	DF96	9/6	ECH81	8/11	EY51	12/6	PY80	8/3	
1S5	7/3	6F13	13/-	7H7	8/-		DK96	9/6	ECL80	13/6	EY86	15/-	PY81	8/6	
1T4	7/3	6F15	13/-	7S7	9/11	14S7	DL96	9/6	ECL82	12/11	EZ80	8/3	PY82	8/6	
3Q4	9/-	6F6M	9/6	7Y4	7/11	19A05	DM70	7/11	EF40	13/11	EZ81	9/11	TDD4	12/6	
3QSGT	9/6	6J5G	2/11	10F9	17/6	25A6G	EB41	8/6	EF41	9/6	GZ32	12/6	UAF42	10/6	
3S4	8/-	6K7G	2/11	12AH7	7/6	25L6GT	EBC41	9/6	EF42	9/6	HY90	7/6	UBF80	9/6	
3V4	8/6	6K8G	7/11	12AH8	9/11	35A5	EB91	5/11	EF50(R)	7/6	KT33C	8/6	UCH42	8/11	
5U4G	6/6	6L18	11/6	12AT6	8/9	35L6GT	EBF80	9/6	EF50	4/11	L63	6/-	UF41	8/-	
5Y3G	8/6	6Q7G	8/11	12J7GT	11/6	35W4	ECC81	8/-	EF80	8/6	PCC84	9/-	UF42	14/6	
5Z4G	9/11	6SN7GT5/11	12K7G	7/6	807	4/11	ECC82	8/-	EF85	8/6	PCF80	12/6	UL41	9/6	
6AG5	6/6	6SK7GT7/11	12Q7G	7/6	807(A)	5/11	ECC83	8/11	EF86	13/6	PCL83	15/6	UL84	9/11	
6AQ5	7/6	6V6G	5/11	12SH7	5/6	954	1/6	ECC84	8/11	EF89	9/11	PEN36C14/6	UY41	7/6	
6AT6	7/6	6X4	6/6	12SJ7	7/6	955	3/11	ECC85	8/11	EF91	6/11	PL33	9/11	UY85	8/11
6BBG	2/11	6X5GT	6/6	12SK7	7/6	AZ31	12/11	ECC86	12/6	EL41	10/-	PL81	16/-	VT52	2/11

ANY PARCEL insured against damage in transit for only 6d. extra per order. Uninsured parcels at customer's risk.

SURPLUS, NEW AND GUARANTEED VALVES
All tested before despatch

Cash with order or C.O.D. only

Postage and packing 6d. per valve extra. Over £3 Free.

S.A.E. with all enquiries

THE MINI-7

Described in May and June issues

Pocket Superhet Radio

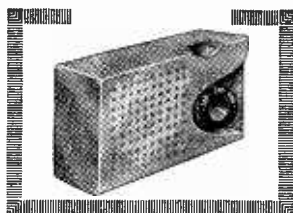

Another winning design from
REPANCO

*Manufacturers of Quality Components
for the Radio Constructor*

REPANCO LIMITED

O'Briens Buildings • 203-269 Foleshill Road
COVENTRY

Price list of specified components for the MINI-7

	£	s.	d.
Repanco group board 17/s and clips	...	5	0
Repanco i.f.t. type XT6—2 off at 10/-	...	1	0
Repanco i.f.t. type XT7	...	10	0
Repanco oscillator coil type XO8	...	5	0
Repanco transformer TT9	...	12	6
Repanco transformer TT10	...	12	6
Repanco ferrite slab aerial FS3	...	7	6
Repanco plastic case and knobs	...	16	0
Sundries kit	...	2	0
J.B. gang type 00	...	9	6
10kΩ miniature pot with s.p. switch	...	5	0
Resistor kit	...	8	6
Condenser kit	...	1	2
Trimmer block	...	2	0
Crystal diode	...	1	6
Three White Spot transistors at 20/- each	...	3	0
Four Red Spot transistors at 10/- each	...	2	0
Rola 2½" speaker	...	1	8
Two Vidor batteries at 10d. each	...	1	8
Long wave coil XL1	...	3	6

All components available from

RADIO EXPERIMENTAL PRODUCTS LTD
33 MUCH PARK STREET • COVENTRY

The Teletron "COMPANION"
COMPLETE KIT

(as spec.) £4.16.0

(Circuit Diagram
9d. post free)

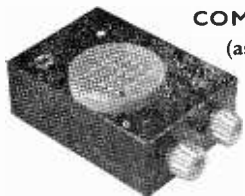

Printed circuit
12/- extra
(Page 879 this issue)

Hi-Gain Band III Pre-amp 41/6, less power pack; 61/6 with power pack

ELEC-RADIO

172a BLACKSTOCK ROAD HIGHBURY
LONDON N5 Telephone CANonbury 1672

5
NEW EDITION

"Basic Mathematics for
Radio and Electronics"

by F. M. Colebrook. B.Sc., D.I.C.,
A.C.G.I., revised and enlarged by
J. W. Head, M.A. (Cantab), 18/4
by post available from **MODERN
BOOK CO.**, 19 Praed Street,
London, W.2. Immediate delivery.

RADIO AMATEURS . . .

get your Licence in

Half The Usual Time!

You must be a good Morse operator!

A "slap-dash" 12 w.p.m. neither satisfies the authorities, yourself nor your operator friends. Morse operating is an exacting art unless your training is made simple and is based on sound fundamentals. For this reason, the Candler System was invented to take the "grind" out of Code tuition, turning a tricky subject into a pleasurable pursuit.

★ Send 3d. stamp for the "Book of Facts"

CANDLER SYSTEM CO

(Dept. 55 RC) 52b Abingdon Rd London W8
Candler System Company Denver Colorado U.S.A.

from one source

Denco, Repanco, J.B., T.C.C., Woden, Elac, McMurdo, Radiospares, Eddystone, Elstone, Bulgin, Belling & Lee, Hunts, Sorad, Acos, Brown, Mullard, Igranic, Cossor, Taylor, Avo, Henley, E.M.I., etc.

Orders dealt with day received

56 page illustrated catalogue No. 11, with 108 photographic illustrations, and over 2,000 new guaranteed lines by leading makers. 9d. post free.

**SOUTHERN RADIO
and ELECTRICAL SUPPLIES**

SORAD WORKS . REDLYNCH . SALISBURY . WILTS

Are You Servicing

RADIO & TV RECEIVERS?

If so you can save time and trouble by dealing with a Wholesaler who specialises in stocking the components of the following manufacturers:—

- A. H. Hunt (Capacitors) Ltd.
- McMurdo Valveholders
- Colvern Potentiometers
- Lab Resistors and Ceramicaps
- T.S.L. Resistors, Speakers, etc.

Trade Catalogue on request

KENDALL & MOUSLEY LTD

Trenoweth House Melville Road
Edgbaston Birmingham 16

HOME RADIO OF MITCHAM

Here's W.B.'s new

HF1016

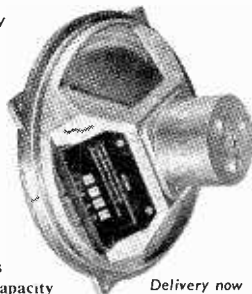

No other speaker
has all these
fine features!

- ★ 10" die-cast chassis
- ★ 10 watts handling capacity
- ★ Universal impedance
- ★ 35 c/s bass resonance
- ★ 16,000 gauss magnet
- ★ Patented cambric cone
- ★ 30-15,000 c/s response

Delivery now
from stock.
Details sent
on request.

£8. 0. 0.

IMPROVE YOUR ITV with the Radio Constructor
Band III pre-amplifier. Amazing results. All parts
in stock—price list on request.

HOME RADIO

(MITCHAM) LTD

Telephone
Mitcham 3282

187 LONDON ROAD • MITCHAM • SURREY

TELETRON Type FX.25

Self-tuned, dual wave
Ferrite rod aerial. 15/- each



Specified for the "Companion" 3 Transistor regenerative pocket receiver.
Type 24 Inductor 3/6 each



TRANSISTOR I.F. TRANSFORMERS

High Q "potted" construction, with Ferrite screw cores. Mounted in screening cans 1" x $\frac{3}{4}$ " dia., 6/6 each. Oscillator coil, 6/6. Transistor type Ferrite rod aerial for MW band, 10/-. Selective crystal diode coil type HAX, 3/- each. Type HAX.L (for LW band), 3/6. Dual wave TRF coils, type A/HF, matched pair, 7/-, with adjustable iron dust cores.

FERRITE ROD AERIALS

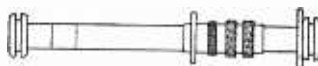

Wound on high permeability Ferroxcube rod. No external aerial required. Full sensitivity. Ideal for battery portable receivers. Medium wave, type FRM 4" x $\frac{5}{16}$ ", 8/9. Dual wave type FRD, 8" x $\frac{5}{16}$ ", 12/9. Miniature R.F. Chokes, wound on iron dust cores, with wire end terminations. 2.5 and 5mH, 3/- each; 10mH, 3/6.

TAPE OSCILLATOR COILS

Type TO.10, TO.10/1, TO.10/2 8/6 each
(as illustrated)

Top Lift Inductor, 200mH,
type TL.2 6/6 each

Bias Rejector Coil, type
BR.10 4/6 each

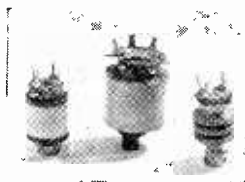

BAND III PRE-AMP COIL SET

(as featured in March issue)

Types 20T, 21T and 22T 9/- per set

Send 5d. in stamps for complete data and circuits. All types available from advertisers in this Magazine and local component stockists

THE TELETRON COMPANY LIMITED

266 Nightingale Road . London N9

Telephone HOW 2527

Trade enquiries to sole distributor

S. Mozer Ltd 288 Hedge Lane N13 Telephone PAL 1748 or EDM 7707

SUB-MINIATURE SPEAKERS

(By W.B.)

1 1/2" round. Depth 1". Impedance 3Ω 27/- tax paid
 2" x 3" elliptical. Depth 1 1/2". Impedance 3Ω 33/- tax paid
 Sub-miniature Output Transformers for above:
Type A single ended, ratio 18.2/1
Type B push-pull, ratio 10.3/1
Type C push-pull, ratio 8/1
 All 3/4" x 7/8" x 3/8" 12/6 each

TRANSISTORS

White Spot (r.f.) ... 20/-
 Yellow/Red (2.8 Mc/s) ... 21/-
 Blue Spot (1.6 Mc/s) ... 15/-
 Yellow/Green (audio) ... 10/-
 Red Spot ... 9/6

We have a large range of Ardenite Sub-miniature components

Special Catalogue available 6d. post free

SUB-MINIATURE VOLUME CONTROLS

Spindle Type, 3/4" diam., 1/4" deep. 2" spindle. 1 or 2 MΩ. Log track ... 4/3
Peripheral Ring Type. Totally enclosed. 3/4" x 1/4" deep. 47kΩ and 1MΩ only ... 2/6
Preset Type. Skeleton assembly. 3/4" diam., 7/8" below panel, 3/8" above panel (including knob). Suitable for manual or screwdriver operation. 5kΩ only ... 2/6
 (See page 705 May issue)

THE "COMPANION" 3 TRANSISTOR RECEIVER

(By Teleton)

Now available with **PRINTED CIRCUIT**
 Complete kit ... £5.15.6
 Details and Price List 6d.

PRICES REDUCED! SUB-MINIATURE CAPACITORS

(By Mullard)

8μF 6V, 25μF 6V, 16μF 125V, 32μF 3V, 5μF 125V, 5μF 40V, 2.5μF 40V, 1.6μF 6V. All at 3/3 each. Also 100μF 6V at 3/- (T.C.C.)

PAPER SUB-MINIATURES
 0.01, 0.001, 0.002μF, 3/4" x 7/8" diam., 8d. each; and 0.005μF (1 1/8" x 1/4" diam.), 7d. each

THE "MINI-7"

(Page 798) June

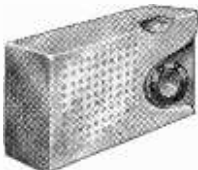

All parts as specified now in stock
 All parts for Stage I ... £5.15.6
 All parts for Stage II ... £1.15.6
 All parts for Stage III ... 14/3
 All parts for Stage IV ... £4.12.6
 Set of nuts, bolts, wire, etc. 2/9
 Send S.A.E. for detailed price list or 1/6 for detailed constructor's envelope and price list

MINIATURE MAINS NEON INDICATORS

With built-in resistor. Domed front with chrome bezel. Only 1" length and 3/8" diam.
 Opal, red or amber 3/10, green 4/7

REPANCO I-VALVER

(Page 653 April)

Constructor's Envelope 9d.
 Complete kit (less 'phones) £2.8.0
 All parts sold separately
 'Phones available at 14/-

AJAX CRYSTAL RECEIVER

Complete kit 14/6. Long wave version 15/- 'Phones 14/- pair. Superior type 16/- (see R.C. March)

CRYSTAL HEADPHONES (by Rothermel) bargain at 21/- pair

HI-GAIN BAND 3 PRE-AMPLIFIER

(See page 568 March)

Resistor Set ... 1/6
 Capacitor Set (with clip) 8/9
 Valve ECC84 ... 17/-
 Rectifier (50mA) ... 7/6
 Transformer ... 13/-
 Coil Set (L-L...) ... 9/-
 Chassis (punched for coils, space for Power Pack) ... 3/9
 Coax Sockets, V/holder, Tag Strip, Nuts, Bolts ... 5/6
COMPLETE KIT AS ABOVE
 £3.3.0

SPECIAL OFFER

Further Reduction

Recording Tape by famous manufacturer, 1,200ft on 7" standard spool
Limited Stock at 21/- each
 (Normal price 35/-)

LITESOLD SOLDERING IRONS

Are specially suitable for those small assemblies. With 1/4" non-wearing bit. Total weight 1/2oz. Mains or battery (state voltage required), 21/6
SOLDER (Multicore) 4d. yard.
 20ft reel 2/6, 1lb reel 14/9. **PRINTED CIRCUIT CORED SOLDER**, 40ft fine gauge 2/6

"THE MERCURY" FM SWITCHED TUNER

(All parts as specified)

Complete front end (ready built, with 2 valves) ... £6.5.0
 Coils, chokes and transformers ... £1.4.6
 Condenser set ... 9/8
 Resistor set ... 5/-
 All other components (including valveholders, diodes, knob, wire, etc.) 16/7
 Complete kit with 2 front end valves but less EF80's ... £9.0.0
 Complete Power Pack kit £2.1.9
All other Jason components stocked

KNOBBS. All types from 10d. Send sketch and sizes for quotation.
TYGAN. Assorted offsets (none less than 3" x 3"). Parcels of 3 sq ft 10/-; 5 sq ft, 15/-.
CAPACITORS. Paper from 10d. Silver Mica from 7d. Assorted mixed s/m and small paper 16/- for 25. **RESISTORS**. All types and ratings from 3d. Wirewound from 1/3. Mixed carbon resistors 1/2 to 1 watt, 20% to 5%, 50 for 7/-, Hi Stabs. 10% 1/2W 6d.; 10% 1W 9d.; 1% 1/2W 2/-. Most usual values available. (A few values in 5%, 2% and 1% available at 1/-.) **P.V.C. WIRING**. Assd. colours, 2d. yd. **FILES**. 6 in plastic wallet, 12/6. **SCREWDRIVERS**. 2 blades, file and bradawl in hollow handle, 2/6. **Mains-tester** type, 4/-. **Flexible blade**, 7/9. **Wallet** containing 3 blades, 2 Phillips blades, 2 bradawls and handle, 12/-. **INSULATING TAPE** 1/2" wide, 25 yds in tin, 1/6. **SWITCHES**. Toggle On/Off, s.p. 2/3. d.p. 3/6; rotary from 2/-. **COIL FORMERS** with **CANS**. Having easily removable coil, 3/4" x 3/4" x 1 1/2" or 2 1/2". 1/6. **SLEEVING**, p.v.c., from 1 1/2d. yd. **FERRITE RODS**, 8" x 1/4" diam., 2/-. **TRANSISTOR HOLDERS**, 1/- each, 5/9 for six, 11/- per dozen

• QUOTATION gladly given. (Please send S.A.E.) • Please add postage to above prices

R. Fagelston (MAIL ORDER)

46 HARDWICKE ROAD • LONDON N13

Build your own 5 Transistor POCKET RADIO (Size 5¼ x 3¼ x 1¼)

using a PRINTED CIRCUIT

Send for **FREE** price list (all parts sold separately) and/or **3/-** for instruction booklet with suggested circuits and assembly details.

OUR CIRCUITS OFFER
HIGH SENSITIVITY
HIGH SELECTIVITY
using:—

3 RF Transistors **1 gn.** each
2 LF Transistors **10/-** each

all specially selected to give
HIGH OVERALL GAIN with AVC

for as little as **£9.18.0** Medium wave
or **£10.6.6** Medium and Long wave

- Miniature Loudspeakers only 27/6
1½" deep x 2⅝" diam.
- Miniature oscillator and I.F. coils 8/-
1½" high ⅝" diam.
- Jackson 00 twin gang tuning condenser with intersection screen 10/6
- Attractive High Impact Polystyrene Cabinet with fittings for tuner, trimmers, speaker and circuit board 8/6

MANY OTHER SUB-MINIATURE COMPONENTS AVAILABLE

SPECIALISED ELECTRONIC COMPONENTS 9-11 MONMOUTH ST · LONDON · WC2

Mail Orders only

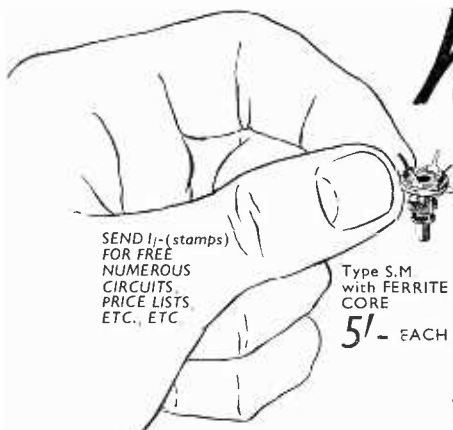

New

**SUB-MINIATURE
HIGH Q COIL
RANGE**

"That's what I call
stupendous performance"

for SUPERHET — T.R.F. —
TRANSISTOR CIRCUITS

OSMOR

Dept. 24 418 BRIGHTON RD. SOUTH CROYDON
SURREY Telephone CROydon 5148/9

TERMS AVAILABLE

17" TV CHASSIS, TUBE & SPEAKER — £19.19.6

17" Rectangular Tube on modified chassis. Supplied as single channel chassis covering B.B.C. channels 1-5, or incorporating Turret Tuner which can be added as an extra, at our special price to chassis purchasers. 50/-, giving choice of any 2 channels (B.B.C. and I.T.A.). Extra channels can be supplied at 7/6 each. I.F.s 10.5-14 Mc/s. Chassis size: 12" x 14½" x 11". Valve line-up: 6SN7G, 6P25, EY51, 2 6D2's, EL38, EL41 and 7 6F1's. Similar chassis were used by well-known rental and hire companies because of their stability and reliability. With tube and speaker, £19.19.6. With all valves, £25.19.6. Complete and working with Turret Tuner, £28.9.6. 12 months guarantee on the tube, 3 months guarantee on the valves and chassis. Ins. carr. (incl. tube), 25/-

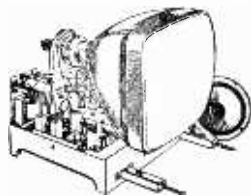

14" TV CHASSIS, TUBE AND SPEAKER — £13.19.6

As above with 14" Round Tube. Chassis, valves and tube guaranteed for 3 months. With tube and speaker, £13.19.6. With all valves, £19.19.6. Complete and working with Turret Tuner, £22.9.6. Ins. carr. (incl. tube) 25/-

RECTANGULAR TV TUBES

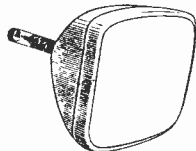

17" £7.10.0 12 MONTHS GUARANTEE 14" £5.10.0

6 months full replacement, 6 months progressive. Made possible by the high quality of our tubes. Ins. carr. 15/6. 9", 10", 14", 15" and 16" round tubes. Our special offer of these sizes, £5. 12" TV Tubes, £6. Thirteen months guarantee on round tubes. Ins. carr. 15/6

End of Season SALE

(REDUCED TO CLEAR)

BOXED VALVES 3 MONTHS GUARANTEE

4D1	2/9	15D2	6/9	ECC81	8/9	EL91	3/9
6B8	3/9	45-1U	10/9	ECH42	8/9	EL84	10/6
6F12	5/9	77	1/9	EF37	4/9	KTW615	9/9
6H6M	1/9	2C22	2/9	EF39	3/9	PEN45	6/9
6P28	10/9	CV188	1/9	EF36	5/9	RL37	1/9
6S7G	3/9	6J5M	2/9	EF50	2/9	SP61	2/9
8D2	3/9	DF66	5/9	EF92	3/9	T41	8/9
12BE6	6/9	EB34	1/9	Z77	7/9	TT11	4/9

TRANSFORMERS

MAINS POWER TRANS. 350-0-350V, 9/9
250mA, 6V heater at 5A, 4V at 5A, 4V centre tapped.
Drop through type. Prim. 200-250V (4½" x 5" x 5").
Post 3/9

MAINS TRANS. 3/9. 350-0-350V 80mA, 4V, 4V heaters. 200-250V prim. Post 2/3

MAINS TRANS. 5/9. 280-0-280V 80mA 6V, 4V heaters. 200-250V prim. Post 2/3

O.P. TRANS. 1/3. Std. size. 2-5 ohms. Post 1/-, 20 for £1. Post 5/6

HOME RADIO—79/6 5 valve (octal) superhet. 3 wave band receiver. Can be adapted for your gram. p.u. at a little extra cost. A.C. size: 9½" x 20½" x 11½". Two a.c./d.c. sizes: 9½" x 18½" x 11½", 9" x 20½" x 12". Wooden cabinets. Ins., carr. 4/6. Please state mains and size required when ordering.

BEAUTIFUL EXTENSION SPEAKERS—29/9

Fitted with 8" p.m. speaker, W.B. or Goodmans, of the highest quality. Standard matching to any receiver (2-5 ohms). Switch and flex included. Unrepeatable at this price. Money back if not completely satisfied. Ins., carr. 3/6

8" P.M. SPEAKERS—8/9

At this price you can have one in every room. Let the lady of the house listen to that radio programme. With o.p. transformer fitted, 10/-, postage 2/9

SUPER CHASSIS—99/6

5-valve superhet chassis including 8" p.m. speaker and valves. Four control knobs (tone, volume, tuning, w/change switch). Four w/bands with position for gram. p.u. and extension speaker. A.C. Ins., carr. 5/6

SOUND AND VISION STRIP, 10/6. Superhet. Complete vision strip. Less valves. Not tested, drawings free. Postage 2/6

POWER PACK AND AMPLIFIER, 19/6. Output stage 6V6 with o.p. trans., smoothed h.t. 350V 250mA, 6.3V at 5A, 22V at 3A, 6.3V at 4A centre tapped. Less valves. Free drawings. Ins., carr. 5/6

SOLO SOLDERING TOOL 19/6

110V or 6V (special adaptor for 200/240V 10/- extra). Automatic solder feed. Including a 20ft reel of Ersin 60/40 solder and spare parts. It is a tool for electronic soldering or in design. Instantly ready in light metal case with full instructions for use. Post 2/9



car wiring. Revolutionary for use and cannot burn.

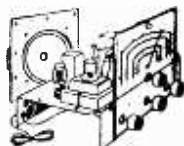

TIMEBASE, 4/9. Complete including scanning coils, focus unit, etc., less valves. Post and packing 2/6

CHASSIS, 1/- each. 6 or 8 valve. Latest type midget valve design for a.m. or f.m. Brand new cadmium plated. Size: 12½" x 7½" x 2½". Post 1/9. 4 for 4/-, post 3/-; 12 for 10/-, carr. 5/-

HEADPHONES, 1/9. Single earphone and band, CL-R type. Ideal for crystal sets, extension on radio, etc. Post 1/3

POWER PACK AND AMPLIFIER, 19/6. Output stage PEN45, o.p. trans., choke. Smoothed h.t. 325V at 250mA, 4V at 5A, 6.3V at 5A, 4V at 5A centre tapped. Less valves. Carr. 5/6

TV MASKS, 14/9. 17" brand new. Grey or white plastic. Good quality. Postage 2/-

GANGED CONDENSERS, 1/9. 2 and 3-gang. Salvage guaranteed. Tested. Postage 1/3

COAX CABLE, 6d. yard. Good quality. Cur to any length, 1/6 post on 20 yards. 45/- per 100 yards, postage 3/6

Send for FREE 1958 Catalogue

Liverpool St. to Manor Park Stn. 10 mins.

OPEN SATURDAY ALL DAY
THURSDAY CLOSED 1 p.m.

DUKE & CO (Dept. 1) 621/3 ROMFORD ROAD MANOR PARK E12 Telephone ILF 6001/3

HENRY'S

(RADIO) LTD.

5 Harrow Road Edgware Road
Paddington London W2

Opposite Edgware Road Station

PADdington 1008/9

OPEN MONDAY to SAT. 9-6 THURS. 1 o'clock

HUNDREDS OF BARGAINS AVAILABLE IN
TRANSISTOR COMPONENTS, VALVES, ETC.
TELETRON and REPANCO Products in Stock
SEND 6d. for 28-PAGE CATALOGUE

TRANSISTORS

JUNCTION TYPE P-N-P

GREEN/YELLOW Audio Frequency Amp. 7/6
WHITE-SPOT 2.5 Mc/s R.F. and I.F. Amp. ... 15/-
RED/YELLOW Osc./mixer I.F. Amp. ... 15/-

MAZDA TRANSISTORS

XA102 8 Mc/s Osc./mixer ... 40/-
XB102 Audio amp. ... 21/-
XC101 Matched output pairs ... pair 60/-

TRANSISTOR BASES 9d. each

TRIPLETT AC/DC POCKET TEST-METER
Type 666H—15 ranges, 1000 ohm p. volt, a.c./d.c
10/50/250/1000/5000V, Milliamps 0-10/100/500, Ohms
0-300/250,000, £5. 10. 0 in new condition with prods
and internal battery



U.S.A. TESTMETER
Type "834-S"

AC/DC 15 Ranges
AC/DC Volts 12/60/
300/600/1200/6000
Milliamps 1.2/12/60/
600

Ohms 0-5,000/5 meg.
F.S.D. 1,000 o.p.v.

£6. 19. 6

Including Batteries

TRANSISTOR SQUARE WAVE GENERATOR

Complete Kit with 2 Transistors, components, circuit
and plastic case 20/-

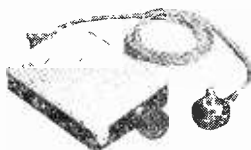

MINI-TWO

2-TRANSISTOR MINIATURE POCKET RADIO
The smallest transistor set offered on the market
Variable tuning. Drilled chassis, plastic case size 3" x
2" x 3/4", miniature hearing aid, 2 transistors and all
components including 3 volt battery, circuits and full
practical layout diagrams.

Total cost 47/6 complete

SPUTNIK-SPECIAL

SHORT-WAVE RECEIVER 10-60 MC/S (5-30
Metres) RECEPTION SET TYPE 208

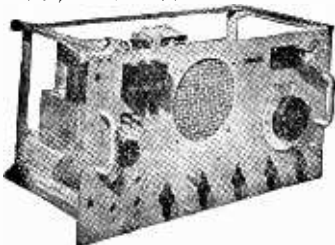

Complete with 6 valves, 2 6K8G, 2 EF39, 6Q7G and
6V6G. Internal mains power pack and 6V vibrator
pack. Built-in 6 1/2" speaker. Muirhead slow-motion
drive. B.F.O. and R.F. stage. I.F. freq. 2 Mc/s
Provision for phones and muting and 600 ohms.
Input 110/250V a.c. 6V vibrator pack included for
battery operation. All sets in new condition
and air tested. £6. 19. 6. Carr. 15/6
BE PREPARED TO LISTEN TO THE SATELLITES

"EAVESDROPPER" THREE-TRANSISTOR POCKET RADIO

(No Aerial or Earth required)

Medium wave, Variable
tuning. Total cost, as
specified, including
Transistors, Transform-
ers, Coils, Condens-
ers and Battery, etc.,
with circuit and plastic
case. All items sold
separately. 70/- POST
FREE. With single
phone 73/6. With Acos
Mike, 82/6. With Min.
Hearing Aid, 86/-

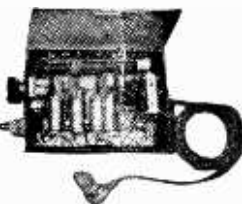

Min. High Impedance Hearing Aid with ear pip... 12/6

Standard Cord for above 3/6

2 1/2 ft Cord fitted with min. Jack Plug and including

Socket 12/6

The above may be used with any of our miniature
transistor portables

TRANSISTOR SIGNAL TRACER

Complete Kit with 2 Transistors, components, phones,
with circuit and plastic case 37/6



"HOMELIGHT" TWO TRANSISTOR PERSONAL PORTABLE

Variable tuning. We can
supply all components,
including two transistors,
diode, resistors, conden-
sers and miniature hear-
ing aid and plastic case,
size 4 1/2" x 2 1/2" x 1 1/8" and
3V battery for
Practical layout 50/-

All items sold separately

"HOMELIGHT III"

As above, but with extra transistor stage, increasing
output, complete with 3 transistors, etc. 58/6

The "TRANSISTOR - 8"

Push-Pull Portable Superhet



COMBINED CAR RADIO & PORTABLE

TWO SETS FOR PRICE OF ONE

TEN STAR FEATURES

- ★ 8 specially selected Transistors
 - ★ 250 Milliwatts output push-pull
 - ★ Medium and Long Waves
 - ★ Internal Ferrite Rod Aerial
 - ★ Highly sensitive
 - ★ Drilled Chassis $8\frac{1}{2}'' \times 2\frac{1}{2}''$
 - ★ Point to point wiring and practical layout
 - ★ Economical. Powered by $7\frac{1}{2}V$ battery
 - ★ Ideal as a car radio
 - ★ Attractive lightweight contemporary case
- Send stamps for Instruction Booklet

All components as specified
can be supplied at an inclusive price of

£11.10.0 p.p. 2/6

Car radio conversion components 8/- extra

This Portable 8-Transistor Superhet is tunable for both Medium and Long Waves and is comparable in performance to any equivalent Commercial Transistor Set. Simplified construction enables this set to be built easily and quickly into an attractive lightweight cabinet supplied.

N.B.—Pair of XC101's for larger output supplied at additional cost of 40/- Call and hear demonstration model

MINI-7 POCKET TRANSISTOR PORTABLE

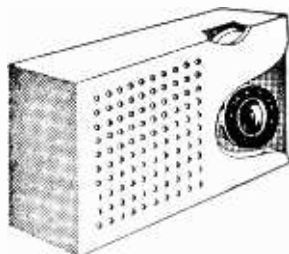

Size $5\frac{1}{4}'' \times 3\frac{1}{8}'' \times 1\frac{1}{4}''$

**ULTRA SENSITIVE!
ECONOMICAL!
HIGHLY SELECTIVE!**

May be Built for **£9.19.6**

SPECIAL FEATURES

- ★ 7 selected transistors
- ★ Internal ferrite aerial
- ★ Operates from 6V battery
- ★ Practical layout
- ★ Drilled chassis
- ★ Long wave 10/6 extra
- ★ Attractive plastic case

TRANSISTOR COMPONENTS!

We stock a large selection of Repanco and Teletron transistor components including osc. and i.f. coils for 315 kc/s and 465 kc/s; many types of ferrite rod and slab aerials; interstage and output transformers; including push-pull types; sub-miniature volume controls and switches; condensers, resistors, chokes; Ardenite hearing aid pieces; Jackson sub-miniature twin gangs; miniature speakers; crystal set coils; transistor set batteries; diodes; transistor bases and of course many types of transistors. A FREE list of these components will be sent on request. Also ask for our free transistor circuits.

HENRY'S RADIO LTD · 5 HARROW ROAD · LONDON W2

Telephone PADDington 1008/9

FULL DISCOUNTS ON TRANSISTORS AND COMPONENTS TO THE TRADE

TECHNICAL TRADING CO

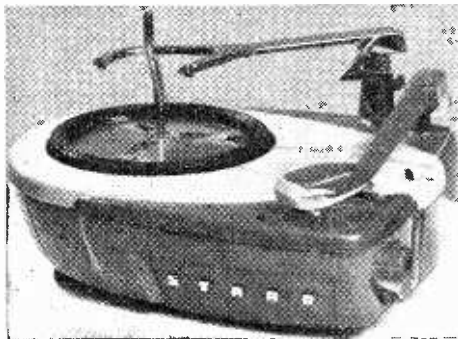

4 SPEED STAAR GALAXY

RECORD PLAYERS as illustrated. Lightweight sapphire turnover pick-ups. Plays 10 records of any size or speed through your radio. 200/250 volts a.c. **£5.15.0** (Post 4/-)

THE BARGAIN OF THE YEAR!

AUTOCHANGERS as above player but less case (post 4/-) (Listed £12.16.0) **£3.19.6**

PORTABLE RECORD PLAYERS consisting of: Galaxy autochanger, excellent 2-valve amplifier, 7" speaker; super portable case similar to that illustrated last month **13 gns.**

GALAXY SPARES. 1,000's in stock at reasonable prices including tone arms, rubber idler-wheels, p.u. cartridges, spindles, springs, motors, etc.

DUAL SAPPHIRE PICK-UP CARTRIDGES **12/6**

ELECTROVOICE Power Point **19/-**

SONOTONE turnover needle type **22/6**

ACOS type GP65-3 **22/6**

STEIG & REUTER (super German equivalent to GP65-3) **17/6**

SCR522 BENDIX TRANSMITTER-RECEIVERS

U.S.A. standard aircraft type 100-140 Mc/s, complete except for valves (all standard types). Ideal 2 metre conversion. **27/6, carr. 6/-**

No. 18 WALKIE-TALKIES, 6-9 Mc/s. Complete all valves 55/-, No. 18 Walkie-Talkies 29/-

TV CABINETS. 14" table with mask glass, front 7" x 4" speaker fret, attractive, **25/-, carr. 4/-**

FOCUS MAGNETS, wide angle, with centreing and mounting, 9/6. Ditto double magnet 12/6
CONDENSERS. U.S.A. 0.1µF 350V metal tub., 6/- doz. 16+16, 350V, small Dubilier, 3/-; 100µF 6V, 1/3; 100+200µF, 275V wkg, can, 5/6; 0.001µF, 18KV 4/6
COSSOR WOBBLATORS, all wave, £9.10.0

TRANSISTORS GUARANTEED

Red Spot (up to 800 kc/s) 7/-

Blue Spot (up to 1.6 Mc/s) 10/-

White Spot (up to 2.5 Mc/s) 14/-

AMPLIFIERS. Parmeko 200/250V a.c. mains, 10/20W complete EF36, ECC31, 2 EL35, 524, untested, £3.15.0. Quality 5 watt amplifiers 615, 617, 6V6, 524, Parmeko mains and output trans., £2.19.0. Ardenite 12V street broadcast 10/20W compact, 2 ECC31, 2 6L6, rotary converter, £4.10.0 Ditto 24 volt £3.15.0

GERMANIUM CRYSTAL DIODES, famous make, tested, 9d., p. and p. 3d., 8/- doz.

IRON SELENIUM RECTIFIERS. 12 volt 1 amp. 4/9; 12 volt 3½ amp, 9/6; 250V 80mA, 5/-; 250V 250mA, 9/6; 500V 50mA, 6/6; 500V 150mA, 9/6; 1,000V 40mA, 8/6

L.F. CHOKES. Good quality, upright mounting, compact, 6H 70mA, 3/6; 20H 80mA, 5/-; 9H 100mA, 4/6; 15H 150mA, 8/-; 10H, 200mA, 9/-; 5H, 250mA, 4/6; 6H 300mA, 6/6

I.F. TRANSFORMERS, midget, 465 kc/s, 5/- pair; standard size 5/- pair

GUARANTEED TV TUBES

(Ex Equipment) All guaranteed 6 months

12" (MW31-74, 3/31, CRM121, etc.) **£5.5.0**

14" (C148M, CRM141, 4/14, MW36-24, etc.) **£4.10.0**

15"-16" (CRM151, 4/1-1, CRM152, etc.) **£5.5.0**

17" (MW43-64, 171K, C178M, etc.) **£6.10.0**

17" (CRM171 only) **£6** (carr. and ins. 12/6)

U.S.A. TRANSMITTERS, Type TBS. 808's modulating 808's (about 10 valves), 100-150 Mc/s, £7.10.0. Receivers to match (about 10 valves), £4.10.0

230V MAINS TRANSFORMERS. 525-0-525V 150 mA, 6.3V 5A, 5V 3A, 25/-, Chokes 10H 150mA, 6/-

POWER PACKS. 230V a.c. in., 2 separate double smoothed outputs of 375, 550 or 620V at 200/250mA, also 6.3V 5A. Sealed cases, 4 5U4G valves, £7.10.0

SIGNAL GENERATORS. B.S.R. LOSOA, 30 c/s-18 kc/s, £12.10.0; TF517F, 150-300 Mc/s, £9

½ **MEG POTS.** D.P. switch, 3½" spindle, 3/6

HT/LT BATTERIES. 60V+1.5V, tested, 3/3

P.M. SPEAKERS. 2½" Celestion, 17/6; 6½" public address type, 12/6; 8" Goodmans, f.m. quality, 19/6; Goodmans 10" x 6", 27/6

12" SPEAKERS. Special offer, standard Plessey make in sealed cartons, 26/-

GUARANTEED RADIO VALVES — 24 HOUR SERVICE

1C6	3/6	6H6	2/-	6SN7GT	5/9	14F6	9/-	EBC3	9/6	EF50(BR)	3/6	HL133DD	PY80	8/6	
1LC6	4/6	6J5M	5/-	6U4GT	12/6	25L6GT	8/6	EBC33	7/-	EF50(AM)			PY81	8/6	
1LN5	4/6	6J5GT	4/6	6V6G	6/-	25Z5	9/6	EBL31	15/-		4/9	HVR2A	5/-	PY82	8/6
2A7	7/6	6J5G	3/-	6V6GT	7/-	35Z4GT	7/6	ECS2	5/6	EF80	11/-	KT44	12/6	PY82	8/6
5U4G	6/6	6I6	4/-	6V6M	7/-	41	9/6	ECC31	9/6	EF85	7/-	KT45	12/6	SP48	9/6
5Z4	9/-	6J7G	5/-	6X4	6/-	42	9/6	ECC81	8/6	EF89	9/6	KTW63	6/-	SP13C	11/-
6A6	4/6	6K7G	4/6	6X5GT	5/-	43	9/6	ECC82	6/6	EF91	6/6	PEN45	15/-	SP41	2/6
6AC7	5/6	6K7M	6/-	7B7	7/6	80	7/6	ECC83	8/6	EF95	8/6	PCC84	9/-	SP61	2/6
6A8	9/-	6K8G	7/6	7C6	7/6	83	7/6	ECC84	10/6	EL32	4/6	PCC85	11/6	TH41	12/6
6AL5	5/6	6L6G	8/-	12A7M	8/6	807(BR)	3/9	ECC85	9/6	EZ80	7/6	PCF80	12/6	U16	9/6
6AM6	6/6	6L7	6/-	12A7	8/-	807(AM)	5/6	ECC86	12/-	HL41	8/6	PEN25	5/-	U22	7/6
6BA6	6/6	6N7	7/-	12AU7	6/6	CBL21	12/6	ECL80	13/6	HL41DD		PL81	13/6	U52	6/6
6BE6	6/6	6SA7M	7/-	12AX7	8/6	CCH35	15/-	EF36	4/-	HL42DD		PL82	9/-	VP41	9/6
6C4	4/-	6S7M	5/6	12J5GT	4/6	EA50	1/6	EF37	7/-		12/6	PL83	11/-	XB1M	9/6
6C6	4/6	6S7M	7/6	12K7GT	6/6	EB34	1/6	EF37A	8/-						
6D6	4/6	6SK7GT	5/-	12Q7GT	7/6	EB91	5/6	EF39	5/-		12/6	PM12M	5/6	Z63	9/-

Postage 1/3 in £1 (2/- in £1 speakers/trans.). Min. 6d. No C.O.D. All items less 5% and post free for a dozen or more
SEND S.A.E. FOR SPECIAL LIST 500 ITEMS — 1,000 UNLISTED SNIPS TO CALLERS AT:

350-352 FRATTON ROAD PORTSMOUTH

(Telephone 4121)

SMALL ADVERTISEMENTS

Readers' small advertisements will be accepted at 3d. per word, including address, minimum charge 2/- Trade advertisements will be accepted at 9d. per word, minimum charge 6/- If a Box Number is required, an additional charge of 2/- will be made. Terms: Cash with order. All copy must be in hand by the 12th of the month for insertion in the following month's issue. The Publishers cannot be held liable in any way for printing errors or omissions, nor can they accept responsibility for the bona fides of advertisers.

PRIVATE

MARINE RECEIVER 3 short wave bands, world reception covering trawler, ground to air, amateur and satellite bands. Medium wave band. Earphones, loudspeaker listening, BFO, gram, mike, r.f. gain, tuning meter and many more features. A real bargain at £45. Must be seen. Contact J. Davies, 20 Bushey Hill Road, London, S.E.5. Phone Rodney 2562.

FOR SALE 19 Set Mk. III, complete with power unit and equipment in working order, £20. Bendix T.C. 12A Transmitter and Receiver, full equipment, needs attention, £15. Judge, 22 Old Park Avenue, Sheffield 8. Telephone Sheffield 46980 after 6 p.m.

FOR SALE AVO 47A with case, £8. Cossor double beam oscilloscope, £20. Mullard oscilloscope £20. Weston 500V 200 Megohm Megger, with internal battery in oak case, £15. E. & V. 250V Megger, £6 10s. BSR LF Signal Generator 0-16 kc/s, £9. Vitavox moving coil mikes, £1. 400-0 400uA 4 1/2 inch moving coil meters, £1 10s. Rotary converters 12-24V d.c. in, 230V 50 c/s, single phase, 200 watts out, £10. Hallierafers HT11, 1 to 3 Mc/s Transmitter Receiver complete with 12V power pack etc., less crystals £20. L. Riches, 110 Luton Road, Chatham, Kent.

FOR SALE Volume 1-3 *Practical Television*, 7s. 6d. per volume. VCR97, chokes, transformers and condensers. S.a.e. S. Peits, 7 Chedworth House, Geldeston Road, London, E.5. Phone AMH 3980.

FOR SALE AVO valve tester with adaptors and latest relevant valve manual, £9. Box No. E175.

FOR SALE Sigma disc recording machine with spares and blanks, £45 o.n.o. 6 Clifford Avenue, Denton, Manchester.

VALRADIO CONVERTER 12V d.c./230V, 150W a.c. £12. New, selling because wrong voltage. Box No. E174.

FOR SALE Power unit 234A, new 5Z4, additional 180V output, £5. Also R109 receiver with magic eye, £3 10s. Both including carriage. Box No. E173.

NEW SURPLUS...

1A3	2/6	6L6M	10/6	803	17/6	EL84	9/-
1L4	5/-	6L7M	7/6	808	17/6	EL91	7/-
2A3	8/6	6Q7GT	9/6	830B	15/-	EM80	10/-
2X2	3/6	6SA7M	7/6	866A	12/6	EZ40	8/6
3A4	5/6	6SG7M	7/6	959	5/-	EZ80	8/6
3Q4	7/6	6SH7M	5/-	1616	5/-	HK24G	25/-
3S4	8/6	6S17M	7/6	1629	4/-	KT33C	9/6
5763	12/6	6SK7M	6/6	EA50	1/6	PCC84	10/6
5B/254M		6SL7GT	7/6	EABC80	10/-	PCF82	10/-
	21/-	6SN7GT	6/6	EAC91	4/6	PL82	9/6
5Y4G	6/6	6SQ7M	7/6	EAF42	10/6	PL83	10/6
6AC7M	5/-	6X4	6/6	EB34	2/6	PCL83	12/6
6AG5	3/6	6X5GT	7/6	EB91	6/6	PY80	8/-
6AK5	5/-	7B7	9/-	EBC33	7/6	PY81	9/6
6AL5	6/6	7C5	9/-	EB41	10/6	PY82	9/6
6AM6	7/6	7C6	9/-	EBF80	10/-	PY83	11/6
6AQ5	8/6	7S7	10/-	EBF89	10/-	R19	12/6
6AT6	8/-	7Y4	8/6	ECC82	9/6	SP61	3/-
6AU6	8/6	12A6M	7/6	ECC83	9/6	TT11	4/-
6B8G	4/6	12A7	8/-	ECC84	11/-	UAF42	10/6
6BA6	8/6	12A7	9/-	ECC85	10/6	UBC41	10/6
6BE6	7/6	12AU6	9/-	ECC80	12/6	UBF89	10/6
6BH6	7/6	12AU7	8/6	ECC82	11/6	UCC85	10/6
6BJ6	7/6	12BE6	8/6	ECH42	10/6	UCH42	10/6
6BR7	11/6	12CBM	7/6	ECH81	10/-	UF41	10/6
6C4	5/-	12Q7GT	9/-	ECL82	12/6	UF89	10/6
6C5M	5/6	12K7GT	9/-	EF36	4/-	UL41	10/6
6F6M	5/6	12SC7M	2/6	EF39	5/-	UY41	8/6
6FBG	4/6	12SK7M	7/6	EF41	10/6	UY85	10/-
6G6G	4/6	12SQ7M	8/6	EF50	3/-	UABC80	
6J5GT	5/-	35L6GT	9/6	EF50(S)	4/6		10/6
6J5M	6/-	35Z4GT	8/6	EF55	7/6	VU39	9/6
6J6	4/-	35Z5GT	8/6	EF80	9/-	VR150/30	
6K7G	5/6	42	7/6	EF85	10/-		7/6
6K8G	8/6	50L6GT	9/6	EF89	10/-	VR116	4/-
6K8M	10/6	80	8/6	EP91	7/6	V570	3/-
6H6M	3/6	446A	10/6	EL32	4/-	XP1.5	3/-
6L6G	9/-	801A	7/6	EL41	10/-	Z77	7/6

SPECIAL OFFER

Units of the Famous R107

- Complete Front End**, r.f. mix. osc., 3 bands 1.2-18 Mc/s with large half-moon calibrated dial and slow-motion drive.
- Power Pack** for either 12V d.c. or 100-250V a.c. input. You only need an i.f. strip and output stage to make a first-class Short Wave Receiver. We offer both units brand new and boxed (less valves and vibrator) for only 52/6 the pair, plus 7/6 carriage

Indicator Units BC929. Ideal for "scope modification. Fitted 3" tube. 3 BP1, 2 6SN7, 2 6H6, 1 6G6, 1 2X2, Dozens of pots, resistors, condensers, etc. Bargain price in good used condition, only 45/- each

Modulator 67. Contains a.c. power pack, input 230V 50 c.p.s., output 350V 120mA (transformer rated 200mA), 6.3V 5A with heavy duty choke. 5Z4, 11 other valves, switches, pots, etc. Brand new, boxed, 39/6 each carr. paid

Transistors. Yellow/green, audio 250mW, 7/6; OC70, 12/6; OC71, 15/-; yellow/red. r.f. to 8 mc/s, 15/-

Midget Mains Transformers (same size as std. spkr. o/p). Input 230/250V, o/p 220V 20mA, 6.3V 0.6A. Ditto but 175V 25mA, both types 11/9 each, post. paid

Transmitter/Receivers. Army Type 17 Mk. 2. Complete with h.r. phones, hand mike and valves. 44-61 Mc/s. In good used condition, 29/6 each. Carr. paid. Few only

SPECIAL OFFER

Performance Meters No. 2. Comprising 230V 50 c/s mains trans. 250-0-250V 30mA, 6.3V 1 1/2A 5V 2A (60mA h.t. may safely be drawn), 20H choke. 5Z4, Y65 magic eye, 2 EF50, 1 EC52, 1 EA50, dozens of components, all in smart grey louvered case 10" x 9" x 9". Made by Parmeko. Brand new and boxed. Unrepeatable component value at only 27/6 each plus 5/- carriage (U.K. only)

Post 9d. Free over £2

S.A.E. Enquiries

JOHN ANGLIN

385 CLEETHORPE ROAD GRIMSBY LINCS
Telephone 56315

continued on page 927

Build your own HI-FI

— with an
entirely
NEW
range of
Hi-Fi
units and
cabinets!



Imagine the pleasure of having this magnificent Hi-Fi equipment in its beautiful contemporary style furniture for your home . . . and experiencing an entirely new realism in sound reproduction. Yet the Emistructor Hi-Fi will save you money and give you all the *extra* fun and satisfaction of building it yourself—and being able to service and maintain it afterwards. Special instruction manuals guide you at each stage and teach you all about the equipment in simple terms as you build. No skill or experience is needed—only a few simple tools.

Emistructor equipment is made to the highest quality standards and is a product of E.M.I.—world famous for sound recording and reproducing equipment.

There is a wide variety of equipment and cabinets at different price levels to suit individual tastes and requirements. The range varies from a complete Hi-Fi installation with separate speaker enclosures to a simple all-in-one compact system for those with more modest requirements. All equipment is suitable for stereo or non-stereo reproduction of records. Full details and complete specifications will be sent with our free Brochure.



Amplifier



Pre-Amplifier

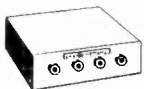

AM/FM Tuner



Tape Recorder



Record Player



Speaker System



Cabinet

FREE BROCHURE - POST TODAY

To: "Emistructor," (Dept. H.F. 179)
43, Grove Park Road, London, W 4.

Please send, with no obligation, details of your
Hi-Fi equipment.

NAME

ADDRESS

IC.126

Jul/58

EMISTRUCTOR

Associated with one of the World's largest recording
organisations comprising—

"HIS MASTER'S VOICE"

CAPITOL · COLUMBIA

PARLOPHONE · MGM · ETC.

SMALL ADVERTISEMENTS

continued from page 925

PRIVATE—continued

FOR SALE Engineer has complete range radio/t.v. service sheets, 4s. each. S.a.e. State Model No. required. C.W.O. H. Kates, 23 Meadway Close, Barnet, Herts.

FOR SALE two tape decks in cabinets, one including amplifier, £15 each. Inspection by appointment, s.a.e. for details. R. Sawyer, 24 Cambert Lane, Gorton, Manchester 18.

SNIP Bendix RA10, speaker, p.p. modified as *Practical Wireless*, Sept. 57, 60s. Buyer collects, London, S.E.24, Box No. E172.

VALVES Used but tested, 3s. each. 6V6, KBC32, KL35, KF35, DL35, 6K7, 5Z4, 35Z4, 6SN7, VP23, 6J5, VR106, W77. Collins, 47 Arnold Road, Tottenham, N.15.

FOR SALE 11T transformer, 2000-1500-0-1500-2000V at 500mA approx, tapped primary 230V, made by R.C.A. £10. 800mA swinging choke 15-60 henry, fully shrouded, 10kV insulation, U.S.A. Manufacture, £2. 300mA Westinghouse potted choke, 10 henry, £1. Universal Avo-minor, a.c./d.c. £5. Loudspeakers, Wharfedale W15/FS, £12 10s.; Super 8 FS/AL 10 ohms, £5. Jason standard FM tuner, £6 15s. Goodmans 750 c.p.s. crossover chokes, 25s. per pair. Meters, 2½ inch flush round, 15mA, 10s.; 50mA, 12s. 6d. 300mA, 15s.; all d.c. moving coil. 15V a.c. moving iron 50 c.p.s., 12s. 6d. Box No. E171.

FOR SALE Valves 5U4G 5s.; 6AG5 2s. 6d.; 6AG7 7s. 6d.; 6AT6 6s.; 6BA6 6s. 6d.; 6BW6 7s. 6d.; 6B4G 4s.; 6B8 1s. 6d.; 6J5 3s. 6d.; 6K7 3s. 6d.; 6F6 6s. 6d.; 6F6G 3s. 6d.; VR91 3s.; VT136 2s. 6d.; VT62 (RCA8019) 7s. 6d.; KT61 5s.; 6SA7 6s. 6d.; 6SJ7 6s.; 6SK7 3s. 6d.; 6X5GT 3s. 6d.; 12AT7 6s. 6d.; 801 7s. 6d.; 807 2s. 6d.; 830B 7s. 6d.; T20 7s. 6d.; RG1-240 10s.; DL92 10s.; post and packing 9d. per valve. Bias pack 120V, with valves, 30s. 1000V 500mA power pack, 19 inch black crackle panel, 150 watt modulator 830B's in push-pull, with preamp and power supply, 19 inch black crackle panel, Packing and postage free, £10 each. Labgear push-pull P.A. Tx coils CCL and DSL for 14 and 28 Mc/s, 7s. 6d. each. "East Keal", Romany Road, Oulton Broad, Lowestoft, Suffolk.

WANTED DST100 manual, offers. H. Hina, 21 Bishops Close, Church Lane, London, E.17.

WANTED Triplett 666H meter switch wafer. R. Pitcher, 84 Tennis Court Drive, Leicester.

TRADE

MORSE CODE TRAINING. Special course for Beginners. Full details from (Dept. RC), Candler System Company, 52 Abingdon Road, London, W.8.

continued on page 928

BRIDGE COMPONENTS

If you require a stockist of High Grade Components, we are the people for the job.

If you are fitting converters, Why not fit the best?

The **Brayhead Turret Converter** available for all channels from stock. Price **£7.7.0**, with adaptor 7/6 each extra. Order, stating channels required (two as specified by you supplied with converter—extra channels **£1.1.0** extra). Normal trade discount—full fitting information available from:

The High Fidelity Co

18 MELVILLE ROAD EDGBASTON
BIRMINGHAM 16

(Proprietors Kendall & Mousley Ltd)

REVAUUMED TV TUBES

SIX MONTHS STRAIGHT GUARANTEE

Mullard		Mazda	
14" MW 36-22	£5.10.0	14" CRM 141	£5.10.0
14" MW 36-24	£5.10.0	14" CRM 142	£5.10.0
14" MW 36-44	£5.10.0	14" CRM 143	£5.10.0
14" AW 36-21	£5.10.0	15" CRM 153	£6.10.0
16" MW 41-1	£7. 0.0	17" CRM 171	£7.10.0
17" MW 43-43	£7.10.0	17" CRM 172	£7.10.0
17" MW 43-64	£7.10.0	21" CRM 211	£10.10.0
17" MW 43-69	£7.10.0	21" CRM 212	£10.10.0
21" MW 53-20	£10.10.0		
21" MW 53-80	£10.10.0		
Cossor		Brimar	
14" 141K	£5.10.0	14" C14BM	£5.10.0
17" 171K	£7.10.0	14" C14FM	£7.10.0
17" 172K	£7.10.0	17" C17BM	£7.10.0
		17" C17FM	£7.10.0
		17" C17JM	£7.10.0

14" Marconi, Emitron, Ferranti, G.E.C. £5.10.0
17" Marconi, Emitron, Ferranti, G.E.C. £7.10.0

Carriage and Insurance 12/6 (U.K.) Cash with order
Personal Callers Welcome

VIDIO REPLACEMENT CO

HALES STREET DEPTFORD HIGH STREET
LONDON SE8

Telephone TIDeway 4506

No connection with any firms of a similar name

Forrest

Transistor Transformers
for Quality Equipment

H. W. FORREST (TRANSFORMERS) LTD
349 Haslucks Green Road Shirley Solihull
Warwickshire Telephone SHrley 2483

GUARANTEED — Over 3,000 in stock VALVES

EF92, EAC91, 6J6, 6CA, 4/6; 6K7, EC91, 5/6; 6AL5,
6SK7, R10, 3A4, 807, 6/-; 6AM6, EL91, 6X4, 6/6; 6BE6,
6CH6, 6F17, 6F33, 7/6; 12AT7, 12AX7, 12AU7, 6BA6,
6BW6, 8/-; 6BR7, 12E1, 85A2, 2D21, 10/-; EF86, 6L6M,
5B/225M, 5B/251M, 11/6

A. A. W. SKILLMAN

79A FRANCHISE STREET WEYMOUTH

BRASS, COPPER, DURAL ALUMINIUM, BRONZE

ROD, BAR, SHEET, TUBE, STRIP, WIRE
3,000 STANDARD STOCK SIZES

No Quantity too Small List on application

H. ROLLET & CO LTD

6 Chesham Place SW1 Telephone SWOane 3463
Also at Liverpool Birmingham Manchester Leeds

H.A.C. THE ORIGINAL SUPPLIERS OF SHORT-WAVE KITS

One-valve Kit, price 25/-, Two-valve Kit, price 50/-,
improved designs with Denco coils. All kits complete
with all components, accessories and full instructions but
less valves. Before ordering, call and inspect a demonstra-
tion receiver, or send stamped envelope for catalogue.

H.A.C. SHORT-WAVE PRODUCTS (DEPT. R)
11 OLD BOND STREET LONDON W1

HIGH FIDELITY

Quality components of all types always in stock for the

MULLARD 2-VALVE PRE-AMPLIFIER and
MULLARD 3-VALVE 3-WATT AMPLIFIER

Circuits free on request

510 AMPLIFIER FM TUNER	circuits 3/6
912 PLUS AMPLIFIER	" 4/-
912 PLUS FM TUNER	" 2/6
RADIO CONSTRUCTOR FM	" 2/-
MERCURY SWITCHED FM	" 2/-
DENCO FM TUNER	" 1/-

Price list available on request

J. T. FILMER 82 DARTFORD ROAD
DARTFORD KENT
Telephone Dartford 4057

BOUND VOLUMES

Vol. 10, August '56 to July '57
inclusive, attractively bound in
blue cloth, with gold blocked
spine, price £1.5.0. post 1/9

DATA PUBLICATIONS LTD

57 MAIDA VALE · LONDON W9

SMALL ADVERTISEMENTS

continued from page 927

TRADE—continued

ILLUSTRATED CATALOGUE No. 13 containing
over 450 items of Government Surplus and Model
Radio Control Equipment, 2s. 2s. Refunded on
purchase of goods, 2s. 6d. overseas seamount—Arthur
Sallis Radio Control Ltd., Department R.C., 93
North Road, Brighton. Telephone 25806.

PANL. recognised for many years as the unique one-
coat black crackle finish. Brush applied, no baking.
Available by post in 4th pint cans at 3s. 9d. from
G. A. Miller, 255 Nether Street, London, N.3.

LEARN as you do it—we provide practical equipment
combined with instructions in Radio, Television,
Electricity, Mechanics, Chemistry, Photography, etc.
Write for full details to E.M.I. Institutes, Dept.
RC47, London, W.4.

JOIN THE INTERNATIONAL S.W. LEAGUE.
Free Services to members including Q.S.L. Bureau
Translation, Technical and Identification Dept.—
both Broadcast and Fixed Stations, DX Certificates,
contests and activities for the SWL and transmitting
members. Monthly magazine, "MONITOR", con-
taining articles of general interest to Broadcast and
Amateur SWL's. Transmitter page and League
affairs, etc. League supplies such as badges, headed
notepaper and envelopes. QSL cards, etc., are
available at reasonable cost. Send for League
particulars. Membership, including monthly maga-
zine, etc., 15s. per annum.—Secretary, ISWL, 86
Barrenger Road, London, N.10.

FREE. Brochure giving details in Home Study Training
in Radio, Television and all branches of Electronics.
Courses for the hobby enthusiast or for those
aiming at the A.M.Brit.I.R.E., City and Guilds,
R.T.E.B., with other Professional examinations.
Train with the college operated by Britain's largest
Electronics organisation. Moderate fees.—Write
to E.M.I. Institutes, Dept. RC28, London, W.4.

SERVICE SHEETS, radio and television, for sale and
hire, s.a.e. enquiries. Valves and components cheap,
list, s.a.e.—J. Palmer (RC), 32 Neasden Lane,
London, N.W.10.

DISAPPOINTED WITH TRANSISTOR CIRCUITS?
Try Morco reflex circuit (2 transistors)—the best of
its kind—loudspeaker results from indoor aerial
(some districts no aerial). All parts available for
Teletron "Companion" and Repanco "Mini-7"
receivers. Send 8d. stamps for notes on transistors.
—Morco Experimental Supplies, 8/10 Granville
Street, Sheffield 2.

INCORPORATED Practical Radio Engineers home
study courses of radio and TV engineering are
recognised by the trade as outstanding and authorita-
tive. Moderate fees to a limited number of students
only. Syllabus of Instructional Text is free. *The
Practical Radio Engineer*, journal, sample copy 2s.
6,000 Alignment Peaks for Superhets, 5s. 9d.
Membership and Entry Conditions booklet, 1s., all
post free from the Secretary, I.P.R.E., 20 Fairfield
Road, London, N.8.

SCOTTISH INSURANCE CORPORATION LTD



62-63 Cheapside
London EC2

TELEVISION SETS, RECEIVERS AND TRANSMITTERS

Television Sets, Receivers and Short Wave Transmitters are expensive to acquire and you no doubt highly prize your installation. Apart from the value of your Set, you might be held responsible should injury be caused by a fault in the Set, or injury or damage by your Aerial collapsing. A "Scottish" special policy for Television Sets, Receivers and Short Wave Transmitters provides the following cover:

- (a) Loss or damage to installation (including in the case of Television Sets the Cathode Ray Tube) by Fire, Explosion, Lightning, Theft or Accidental External Means at any private dwelling-house.
- (b) (i) Legal Liability for bodily injury to Third Parties or damage to their property arising out of the breakage or collapse of the Aerial Fittings or Mast, or through any defect in the Set. Indemnity £10,000 any one accident.
- (ii) Damage to your property or that of your landlord arising out of the breakage or collapse of the Aerial Fittings or Mast, but not exceeding £500.

The cost of Cover (a) is 5/- a year for Sets worth £50 or less, and for Sets valued at more than £50 the cost is in proportion. Cover (b) and (ii) costs only 2/6 a year if taken with Cover (a), or 5/- if taken alone.

Why not BE PRUDENT AND INSURE your installation—it is well worth while AT THE VERY LOW COST INVOLVED. If you will complete and return this form to the Corporation's Office at the above address, a proposal will be submitted for completion.

NAME (Block Letters) _____

If Lady, state Mrs. or Miss _____

ADDRESS (Block Letters) _____

/JB

YOU CAN RELY ON US



The New AVO MULTIMINOR

A first quality pocket instrument

Sensitivity 10,000 Ω/V 0 to 1A in five ranges, 0 to 1,000V in 7 ranges. A.C. volts 0-1,000 in 5 ranges. Resistance 0-2 Meg in two ranges.

PRICE £9.10.0 Leather Case 32/6
or 63/4 Deposit and 6 Payments of 22/2 or 9 monthly payments of 23/3

ALL AVO INSTRUMENTS IN STOCK

COSSOR HI-FI AMPLIFIER KIT

3 valve 3W, Printed Circuit, twin speaker. Beautifully kitted by Cossor Radio and Television Ltd to the last nut and bolt.

COMPLETE KIT or 65/- Deposit and 6 monthly Payments of 23/4
£9.15.0 or 23/10 Deposit and 8 monthly Payments of 23/10

82 SOUTH EALING ROAD
LONDON W5 Telephone EAL 5737

RADIO SERVICING CO

219
RADIO



BOOKS

Tape and Wire Recording. A selection of articles reprinted from the pages of *The Radio Constructor*, covering both the theory and practical applications. A really useful book on this latest development of the hobby.

4th Edition, 3/-. Postage 4d

TV Fault Finding. Profusely illustrated with photographs taken from a television screen depicting the faults under discussion, and containing a wealth of technical information, with circuits, enabling those faults to be eradicated.

5/-. Postage 5d

FM Tuner Units for Fringe and Local Area Reception. Including optional Tuning Indicator and circuit of Osram 912 Amplifier.

2/-. Postage 4d

The Argonaut AM/FM MW/VHF Tuner Receiver. Describing the construction, alignment, and other details of a high quality tuner (or complete receiver), together with map of present and projected coverage areas.

2/-. Postage 4d

Radio Amateur Operator's Handbook. An indispensable aid to the amateur transmitter and listener, containing all details of information which are constantly required. Prefix Lists, Zone Boundaries, Call Areas, Codes, and Mileage Tables, together with Maps and much other useful operating data.

1957/8 edition, 3/-. Postage 4d

Mercury Switched Tuned FM Tuner Unit. A stable unit employing automatic frequency control and a *ready built* front end.

2/-. Postage 2d

Radio Control for Model Ships, Boats and Aircraft, by F. C. JUDD, G2BCX. A comprehensive work on this fascinating subject.

Standard edition 8/6. Postage 7d

Cloth bound edition 11/6. Postage 8d

The "Eavesdropper." A miniature transistor local station receiver. Complete constructional details of this pocket portable.

1/6. Postage 2d

Radio Control Mechanisms, by RAYMOND F. STOCK. The only book dealing solely with this important part of radio control.

4/6. Postage 4d

All available from your local bookseller, or from

DATA PUBLICATIONS LTD

57 MAIDA VALE LONDON W9

Telegrams **Databux London**

Telephone **CUNningham 6141 (2 lines)**

Published in Great Britain by the Proprietors and Publishers

Data Publications Ltd 57 Maida Vale London W9

Printed by A. Quick & Co. (Printers) Ltd 125 High Holborn London WC1 England also at Clacton-on-Sea
Obtainable abroad through the following Collets Subscription Service Continental Publishers & Distributors Ltd
William Dawson & Sons Ltd Australia and New Zealand Gordon & Gotch Ltd South Africa Central News Agency
Holland "Radio Electronica"

Registered for transmission by Magazine Post to Canada (including Newfoundland)

www.americanradiohistory.com